

CORVAIR HOWLITE CON MANETAS

U8G-6590

2-hole basin mixer with spout and mixer, with waste

THG[®]
PARIS

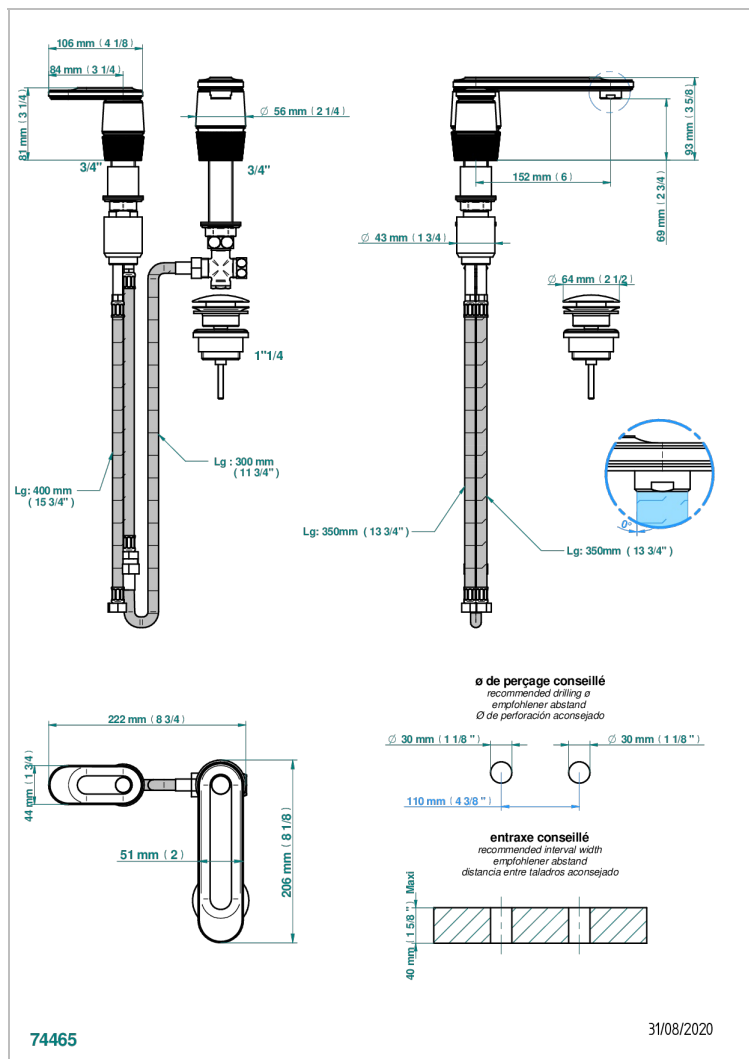
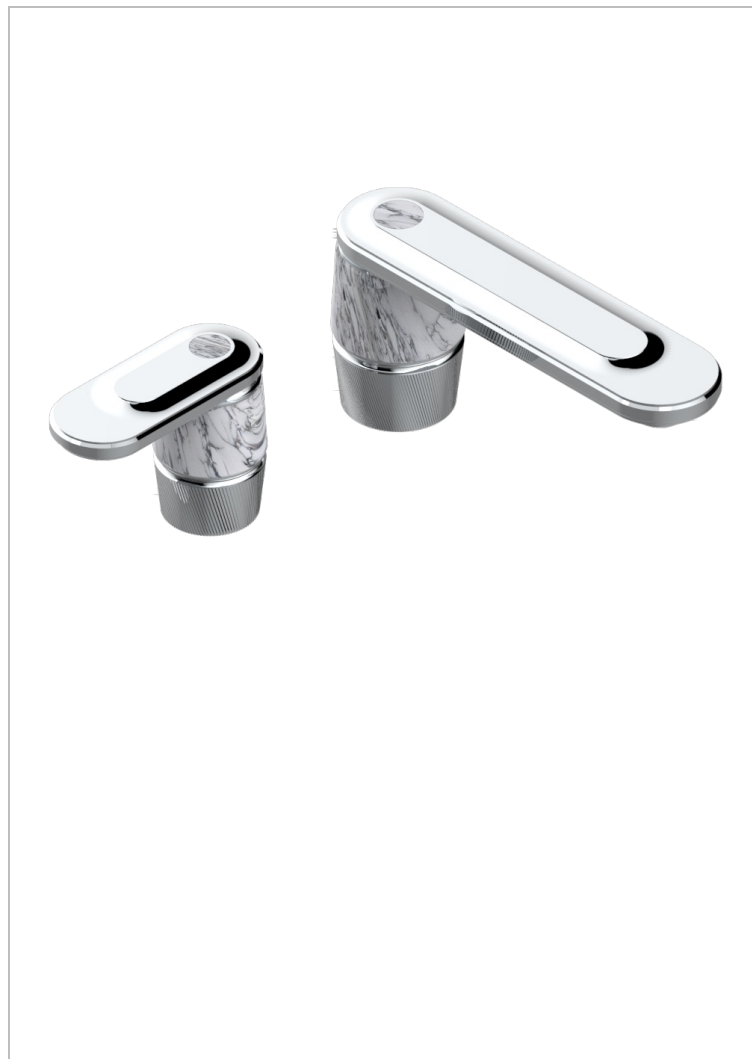

CARACTERÍSTICAS

- Corvaire Howlite con manetas
- 2-hole basin mixer with spout and mixer, with waste

ESPECIFICACIONES TÉCNICAS

- Recommandé : 3 bars (max. 5 bars) - Advised : 43,5 psi (max. 72 psi)
- 15 l/min à 3 bars (4 gpm at 43.5 psi)

ACABADOS DISPONIBLES

Bronce claro - D01
Cerámica negra mate - D30
Cromo - A02
Cromo mate - C02
Dorado - F01
Dorado mate - F07

Dorado pálido - F30
Dorado pálido mate (sin barniz) - F31
Níquel - B01
Níquel mate - C01
Pvd blush - H62
Pvd blush mate - H60

Pvd color latón - H49
Pvd color latón mate - H50
Pvd color níquel - H55
Pvd color níquel mate - H56
Pvd color oro - H52
Pvd color oro mate - H53

Pvd grafito - H64
Pvd grafito mate - H65
Pvd marrón bronce - F33
Pvd marrón bronce mate - F34
Pvd umber - H66
Pvd umber mate - H67