

# CORVAIR PORTORO WITH LEVER

U8J-151

Rim mounted 3-hole basin mixer with waste

THG<sup>®</sup>  
PARIS

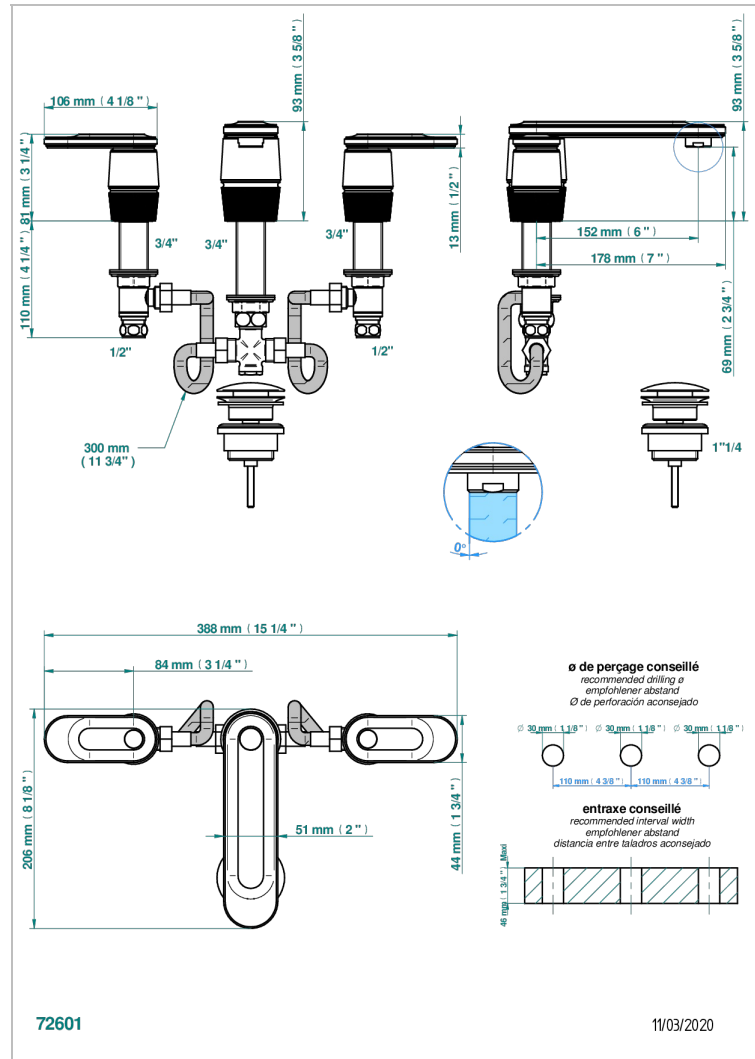

## CHARACTERISTIC

- ACS : 18ACCLY393
- NF : NF EN 200 - IA - Chrome

## STANDARDS



## TECHNICAL SPECS

- Recommandé : 3 bars (max. 5 bars) - Advised : 43,5 psi (max. 72 psi)
- 15 l/min à 3 bars (4 gpm at 43.5 psi)

## AVAILABLE FINITIONS

Black ceram - D30  
Blush PVD - H62  
Brass color PVD - H49  
Brown bronze color PVD - F33  
Gold color PVD - H52  
Graphite PVD - H64

Lacquered light bronze - D01  
Matt Umber PVD - H67  
Matt blush PVD - H60  
Matt brass color PVD - H50  
Matt brown bronze color PVD - F34  
Matt chrome - C02

Matt gold - F07  
Matt gold color PVD - H53  
Matt graphite PVD - H65  
Matt nickel (color finish) - C01  
Matt nickel color PVD - H56  
Nickel color PVD - H55

Polished chrome (color finish) - A02  
Polished gold (color finish) - F01  
Polished nickel - B01  
Soft gold - F30  
Soft matt gold - F31  
Umber PVD - H66