

WEST COAST BLACK ONYX WITH LEVER

U9F-5600BE

THG温控龙头配件，带关闭功能和三个出水口，型号

THG
PARIS

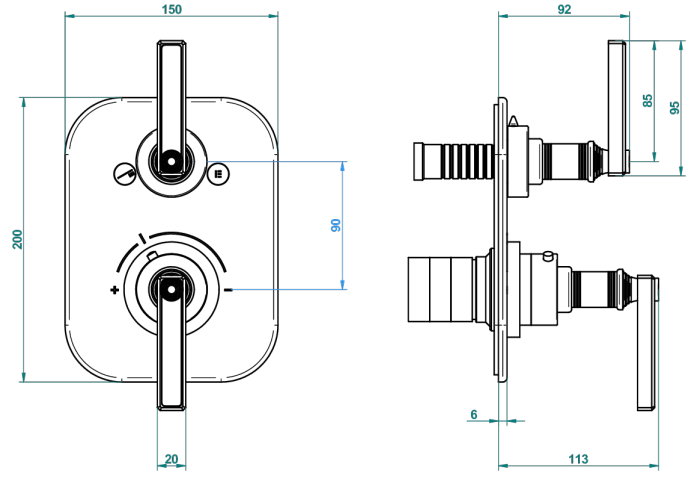
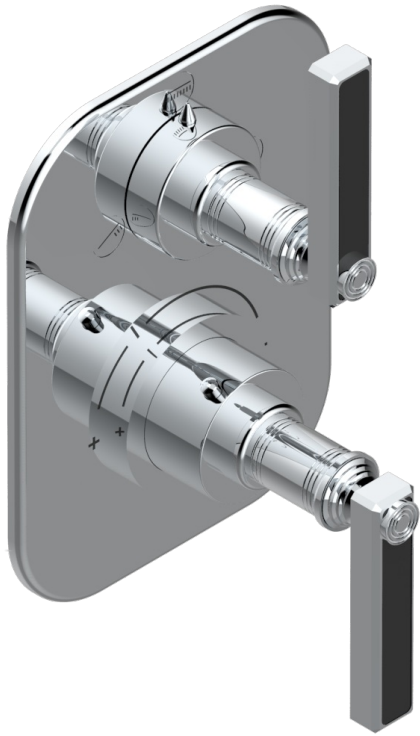

4 pastilles inclus / 4 pads included



Compatible with



5600AE
5600AE/US
5600AE/W

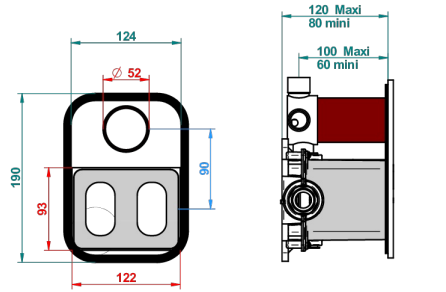

Boite / Box Joint Plaque / Seal Plate Tube

62780

05/12/2017

特色

- ASME : ASME A112.18.1-2011/CSA B125.1-11
- DVGW : DW-6512CQ0608

标准



相关的SKU

- Ref. G00-5100G THG温控龙头温度制动环，含固件组
- Ref. G00-5600AE THG嵌入式温控龙头主体，含蜡元件阀芯，带关闭功能和分水器，三个出水管（关闭阀位于出水管之间），含安装盒

可选饰面

Black ceram - D30
Blush PVD - H62
Graphite PVD - H64
Matt Umber PVD - H67
Matt blush PVD - H60
Matt graphite PVD - H65

Natural smoked Brass - A13
PVD哑光棕铜 - F34
PVD哑光金 - H53
PVD哑光铜 - H50
PVD哑光镍 - H56
PVD抛光铜 - H49

PVD棕铜 - F33
PVD金色 - H52
PVD镍 - H55
Umber PVD - H66
哑光复古铜 - H07
哑光浅金 - F31

哑光金 - F07
哑光铬 - C02
哑光镍 - C01
复古镍 - H28
抛光金 (24K金) - F01
抛光铬 - A02

抛光镍 - B01
浅金 - F30
漆面铜 - D01