

# INFINI PORCELANA BLANCA

U2D-6590

2-hole basin mixer with spout and mixer, with waste

THG<sup>®</sup>  
PARIS

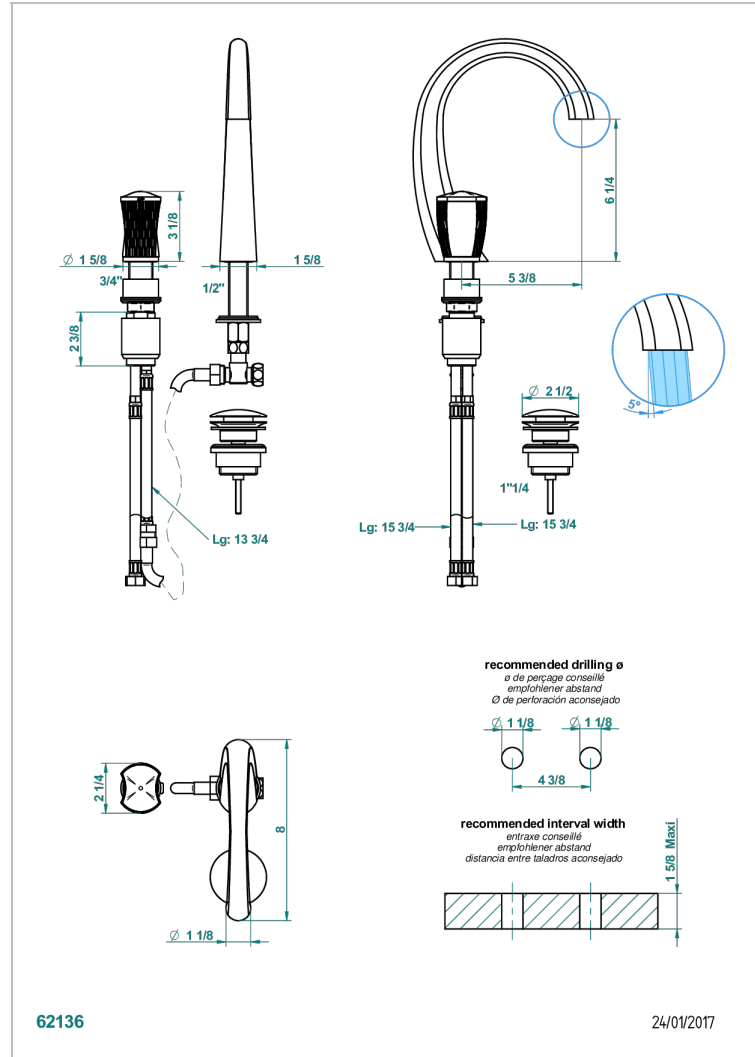
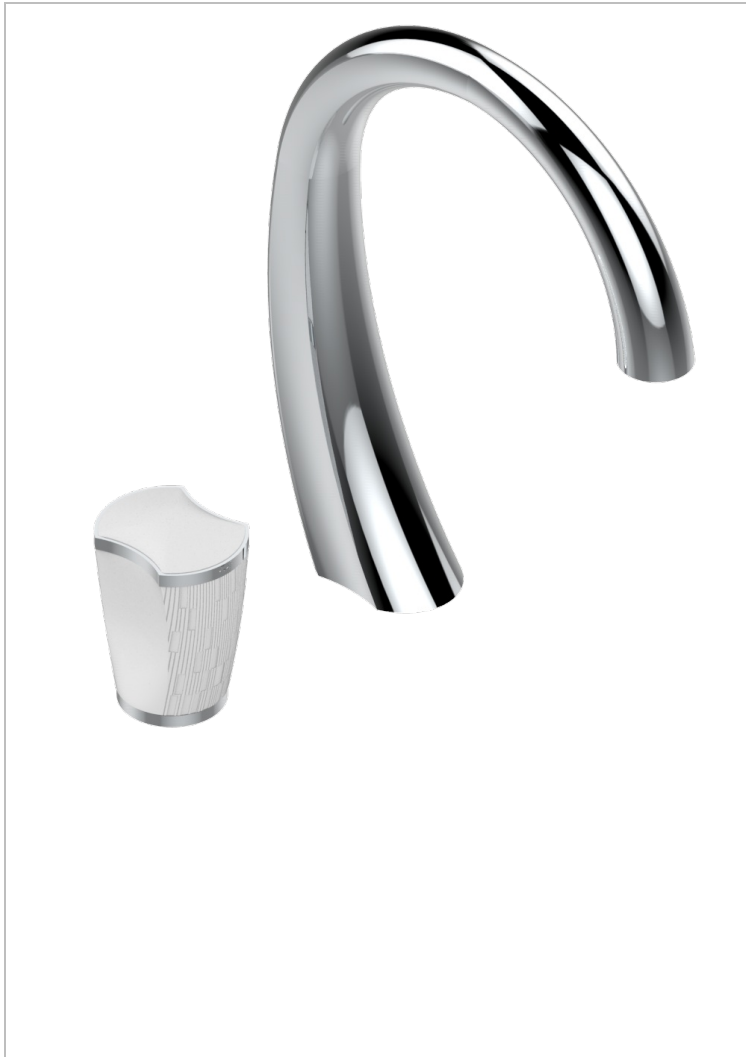

## CARACTERÍSTICAS

- Infini porcelana blanca
- 2-hole basin mixer with spout and mixer, with waste

## ESPECIFICACIONES TÉCNICAS

- Recommandé : 3 bars (max. 5 bars) - Advised : 43,5 psi (max. 72 psi)
- 8,3 l/min à 3 bars (2.2 gpm at 43.5 psi)

## ACABADOS DISPONIBLES

Bronce claro - D01  
 Cerámica negra mate - D30  
 Cobre viejo mate - H07  
 Cromo - A02  
 Cromo mate - C02  
 Dorado - F01

Dorado mate - F07  
 Dorado pálido - F30  
 Dorado pálido mate (sin barniz) - F31  
 Niquel - B01  
 Niquel mate - C01  
 Niquel viejo - H28

Pvd blush - H62  
 Pvd blush mate - H60  
 Pvd color latón - H49  
 Pvd color latón mate - H50  
 Pvd color níquel - H55  
 Pvd color níquel mate - H56

Pvd color oro - H52  
 Pvd color oro mate - H53  
 Pvd grafito - H64  
 Pvd grafito mate - H65  
 Pvd marrón bronce - F33  
 Pvd marrón bronce mate - F34

Pvd umber - H66  
 Pvd umber mate - H67