

GRAND CENTRAL METAL WITH LEVER

U9L-52A

固定托架, 1.5米软管和花洒

THG[®]
PARIS

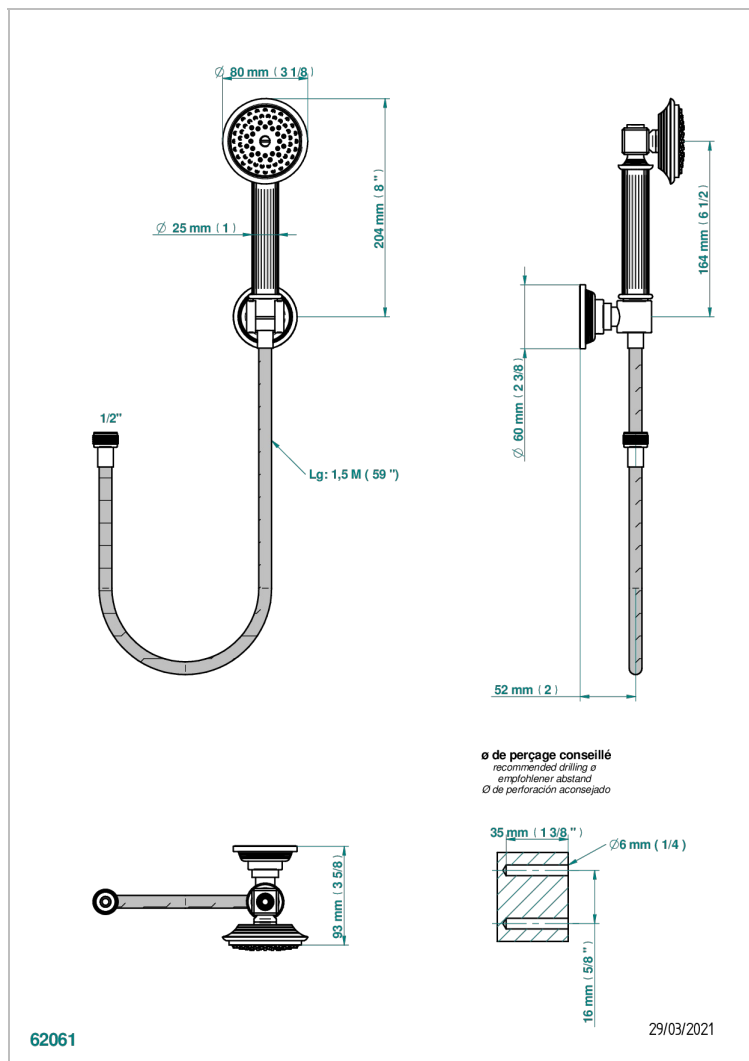

特色

- Grand central Metal with lever
- 固定托架, 1.5米软管和花洒

技术特征

- Recommandé : 3 bars (max. 5 bars) - Advised : 43,5 psi (max. 72 psi)
- 9,5 l/min à 3 bars (2.5 gpm at 43.5 psi)

可选饰面

Black ceram - D30
Blush PVD - H62
Graphite PVD - H64
Matt Umber PVD - H67
Matt blush PVD - H60
Matt graphite PVD - H65

Natural smoked Brass - A13
PVD哑光棕铜 - F34
PVD哑光金 - H53
PVD哑光铜 - H50
PVD哑光镍 - H56
PVD抛光铜 - H49

PVD棕铜 - F33
PVD金色 - H52
PVD镍 - H55
Polished chrome with gold inlay - GA1
Umber PVD - H66
哑光复古铜 - H07

哑光浅金 - F31
哑光金 - F07
哑光铬 - C02
哑光镍 - C01
复古镍 - H28
抛光金 (24K金) - F01

抛光铬 - A02
抛光镍 - B01
浅金 - F30
漆面铜 - D01