

# NANO WITH LEVER

G5B-5400BE

Trim for THG thermostat with 2 valves - ref. 5 400AE with box for rough parts

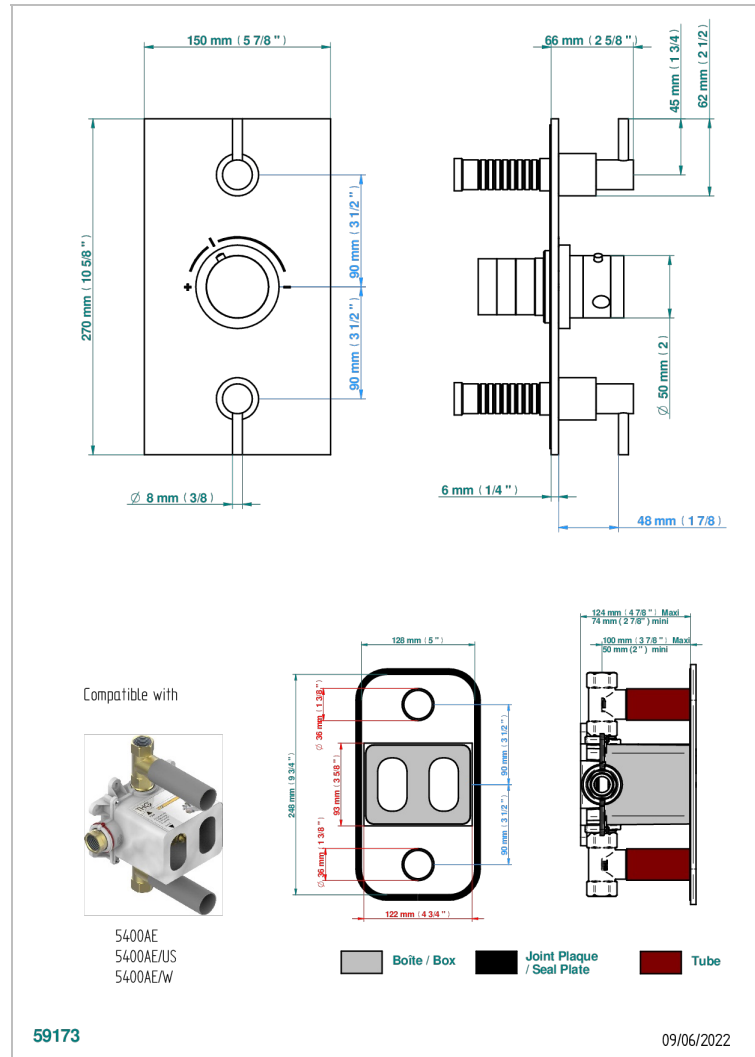
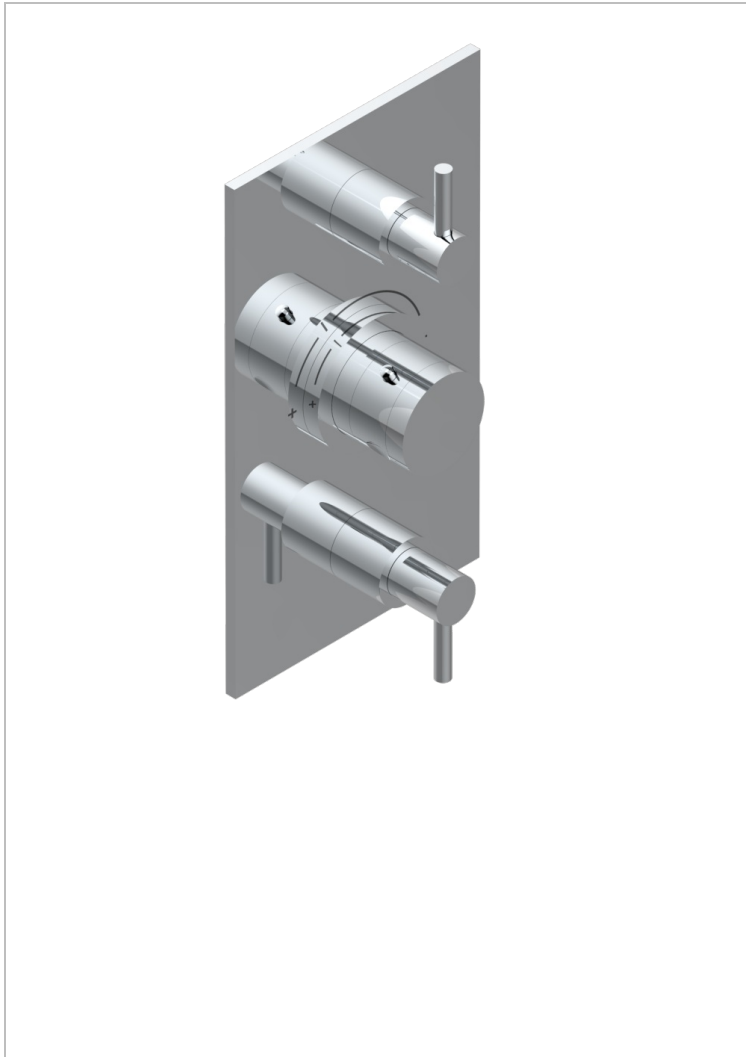

## CHARACTERISTIC

- Built-in thermostatic cover for 5400AE - 5400AE/W - 5400AE/US with 2 no. 3/4" outputs
- Requires concealed thermostat réf 5400AE - 5400AE/W - 5400AE/US
- For shower 2 simultaneous functions
- Temperature control knob with security stop at 38°C
- Solid brass plate and knob
- ASME : ASME A112.18.1-2011/CSA B125.1-11
- DVGW : DW-6512CQ0608

## STANDARDS



## RELATED SKU'S

- Ref. G00-5100G Reinforced stop ring for THG thermostatic with fixing set
- Ref. G00-5400AE/W 3/4" THG thermostat with two valves with wax cartridge delivered with a built-in box, without trim - WRAS approved

## AVAILABLE FINITIONS

Antique nickel - H28  
Black ceram - D30  
Matt chrome - C02  
Matt gold - F07  
Matt nickel (color finish) - C01  
Polished chrome (color finish) - A02

Polished chrome / Polished gold (color finish) - G02  
Polished gold (color finish) - F01  
Polished nickel - B01  
Soft gold - F30  
Soft matt gold - F31