

# NANO WITH LEVER

G5B-5600BE

THG<sup>®</sup>  
PARIS

Trim for THG thermostat with stop valve and 3 way diverter,- ref. 5 600AE with box for rough parts

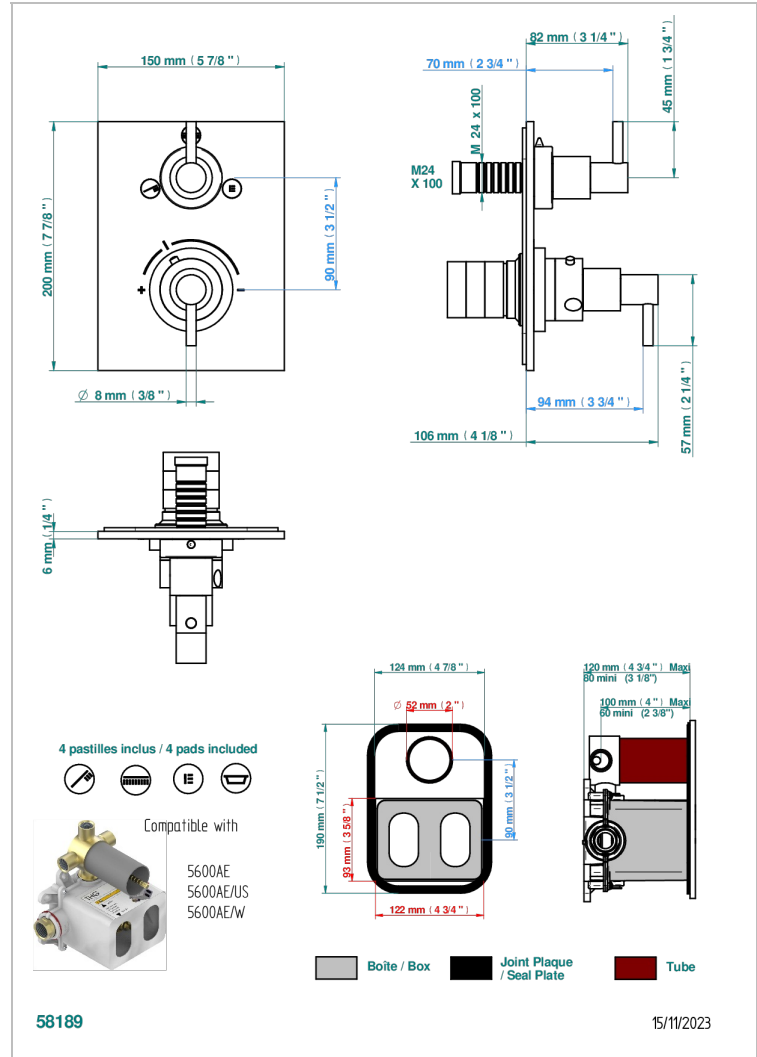
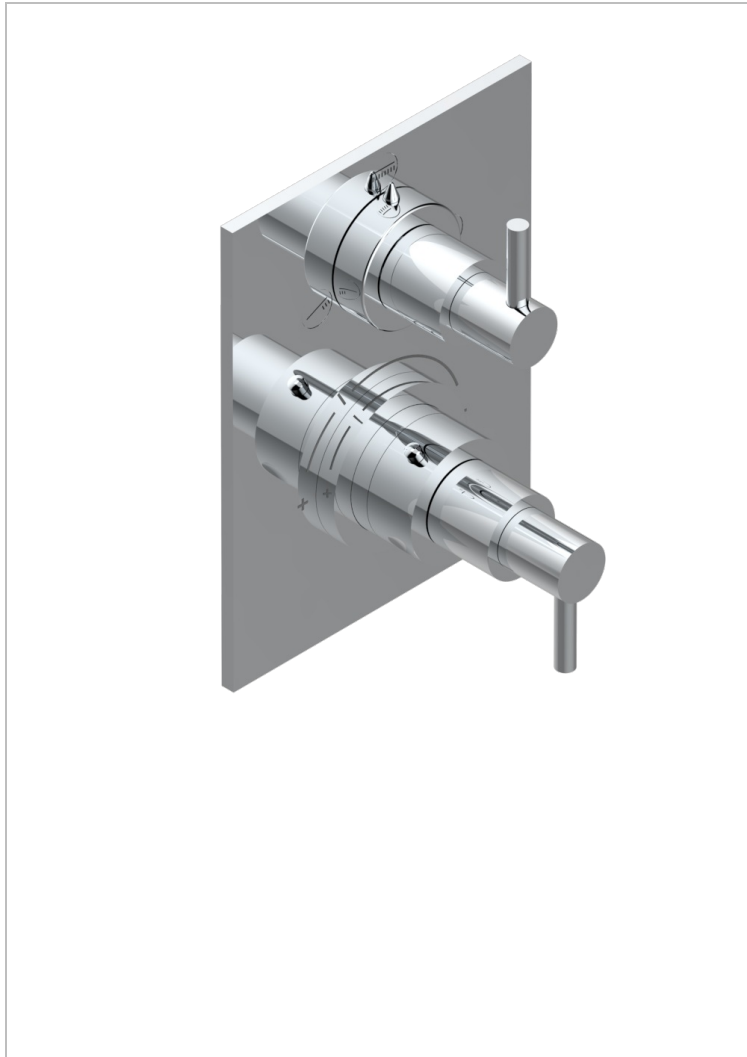

## CHARACTERISTIC

- Built-in thermostatic cover for 5600AE - 5600AE/US - 5600AE/W with 3 no.1/2" outputs (stop function between each position)
- Requires concealed thermostat Ref 5600AE - 5600AE/US - 5600AE/W
- For Shower 3 functions - non simultaneous -
- Temperature control knob with security stop at 38°C
- Solid brass plate and knob
- ASME : ASME A112.18.1-2011/CSA B125.1-11
- DVGW : DW-6512CQ0608

## STANDARDS



## RELATED SKU'S

- Ref. G00-5100G Reinforced stop ring for THG thermostatic with fixing set
- Ref. G00-5600AE 3/4" THG thermostat with wax cartridge, with stop valve and 3 outlets (stop position between outlets), delivered with a built-in box, no trim

## AVAILABLE FINITIONS

Antique nickel - H28  
Black ceram - D30  
Matt chrome - C02  
Matt gold - F07  
Matt nickel (color finish) - C01  
Polished chrome (color finish) - A02

Polished chrome / Polished gold (color finish) - G02  
Polished gold (color finish) - F01  
Polished nickel - B01  
Soft gold - F30  
Soft matt gold - F31