

GENERAL ITEMS

G00-5300AE

3/4" THG thermostat, 60 l/mn with wax cartridge, with valve delivered, with a built-in box, no trim

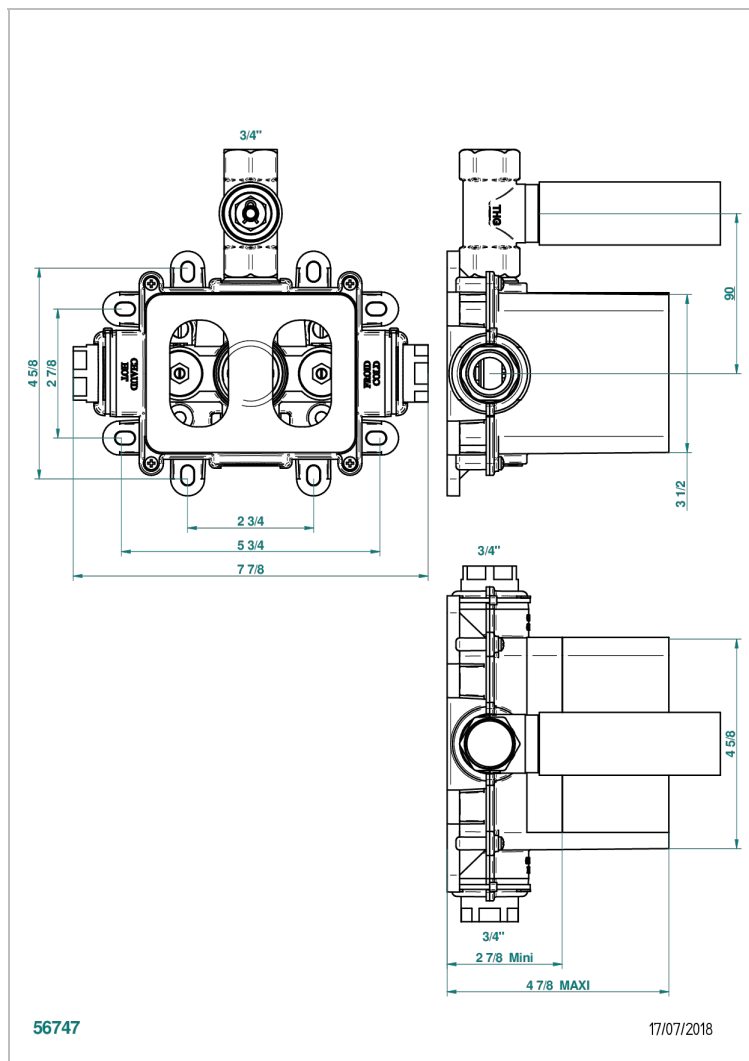
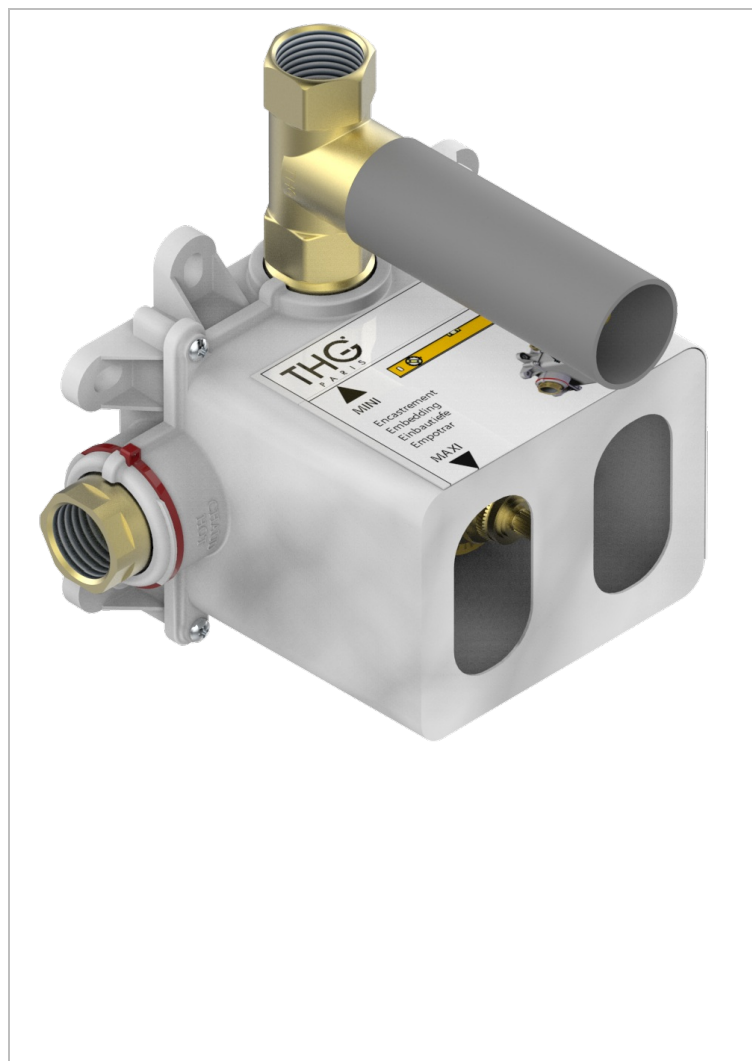

CHARACTERISTIC

- Brass Body
- Encased with protective cover and recessed box
- 1 female output 3/4" with stop valve 3/4"
- thermostatic cartridge with wax element - ref C5200
- Ceramic disk head 1/4" turn of 3/4" - ref 2112C
- Associated product: thermostatic cover plate and on/off valves ref: 5300BE
- ACS : 17ACCLY141
- DVGW : DW-6512CQ0608
- NF : NF EN 1111 - IB - Brut
- SVGW-SSIGE : 1802-6724

TECHNICAL SPECS

- Recommandé : 3 bars (max. 5 bars) - Advised : 43,5 psi (max. 72 psi)
- 55 l/min à 3 bars (14.5 gpm at 43.5 psi)

STANDARDS



AVAILABLE FINITIONS

*** - A00