

GENERAL ITEMS

G00-5400AE/W

THG
PARIS

3/4" THG thermostat with two valves with wax cartridge delivered with a built-in box, without trim - WRAS approved

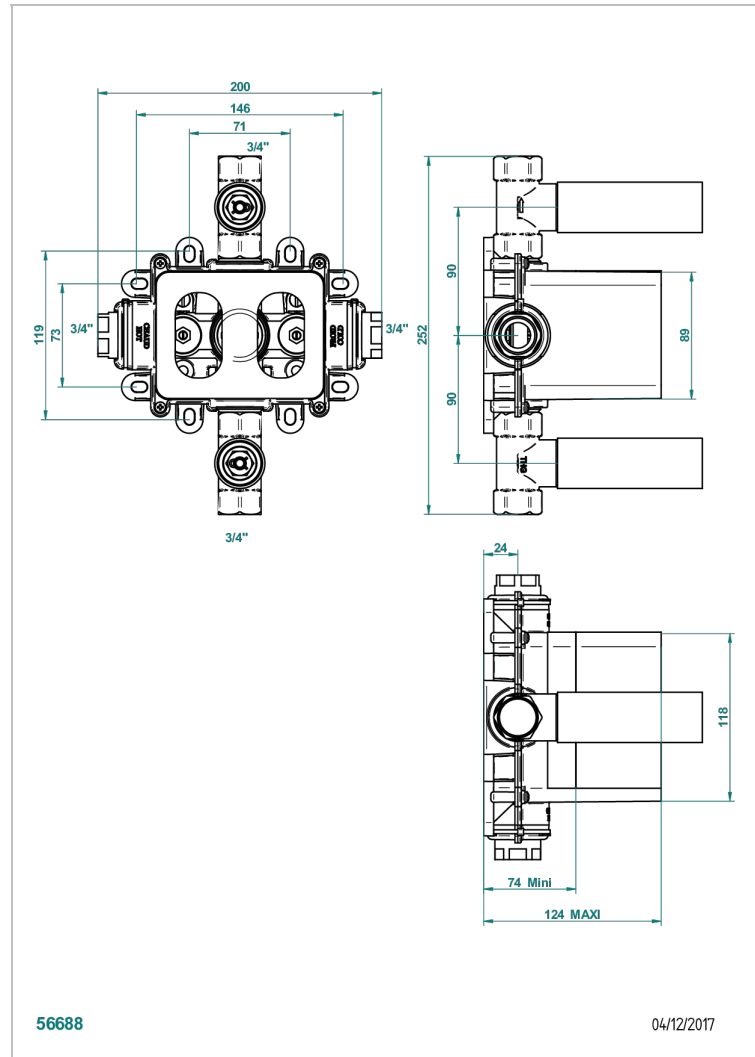

CHARACTERISTIC

- Brass Body
- Encased with protective cover and recessed box
- 2 female outputs with 3/4" stop valve 3/4" can operate simultaneously
- thermostatic cartridge with wax element - Ref. C5200
- Ceramic disk head 1/4" turn of 3/4" - Ref. 2112C
- Associated product: thermostatic cover plate and on/off valves - Ref. 5400BE
- WRAS : 2205019

STANDARDS



TECHNICAL SPECS

- Recommandé : 3 bars (max. 5 bars) - Advised : 43,5 psi (max. 72 psi)
- débit 1 fonction utilisée : 55 l/min à 3 bars - 1 function used : 14.5 gpm at 43.5 psi
- débit 2 fonctions utilisées : 55 l/min cumulés - 2 functions used : 14.5 gpm at 43.5 psi cumulated

AVAILABLE FINITIONS

*** - A00