

GENERAL ITEMS

G00-5540AE

Thg thermostat with wax cartridge, 3 functions with stop valve and 2 outlets (stop position between outlets) and another stop valve, delivered with a built-in box, no trim

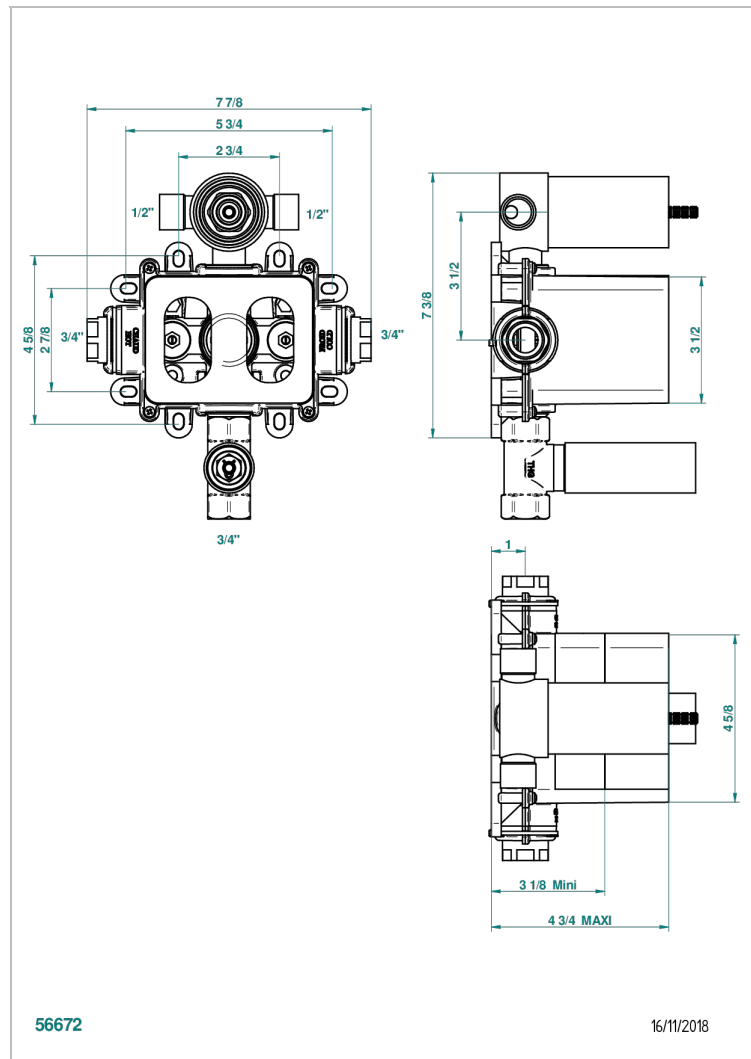

CHARACTERISTIC

- Brass body
- Encased with protective cover and recessed box
- Diverter with 1 stop function and 2 n° 1/2' female outputs - Ref. 2505/S
- 1 outlet downwards with 3/4' female stopvalve - Ref. 2112C
- Ceramic disk head 1/4' turn of 3/4' - Ref. C5200
- Associated product : thermostatique cover plate and on/off valves - Réf. 5540BE
- ACS : 17ACCLY141
- DVGW : DW-6512CQ0608
- NF : NF EN 1111 - IB - Brut
- SVGW-SSIGE : 1802-6724

STANDARDS



TECHNICAL SPECS

- Recommandé : 3 bars (max. 5 bars) - Advised : 43,5 psi (max. 72 psi)
- Débit inverseur seul à 40 l/min à 3 bars - Function diverter only : 10.5 gpm at 43.5 psi
- Débit robinet d'arrêt seul à 55 l/min à 3 bars - Function wall valve only : 14.5 gpm at 43.5 psi
- Débit 2 fonctions utilisées : 55 l/min à 3 bars cumulés - 2 fonctions used : 14.5 gpm at 43.5 psi cumulated

AVAILABLE FINITIONS

*** - A00