

GENERAL ITEMS

G00-5600AE

3/4" THG thermostat with wax cartridge, with stop valve and 3 outlets (stop position between outlets), delivered with a built-in box, no trim

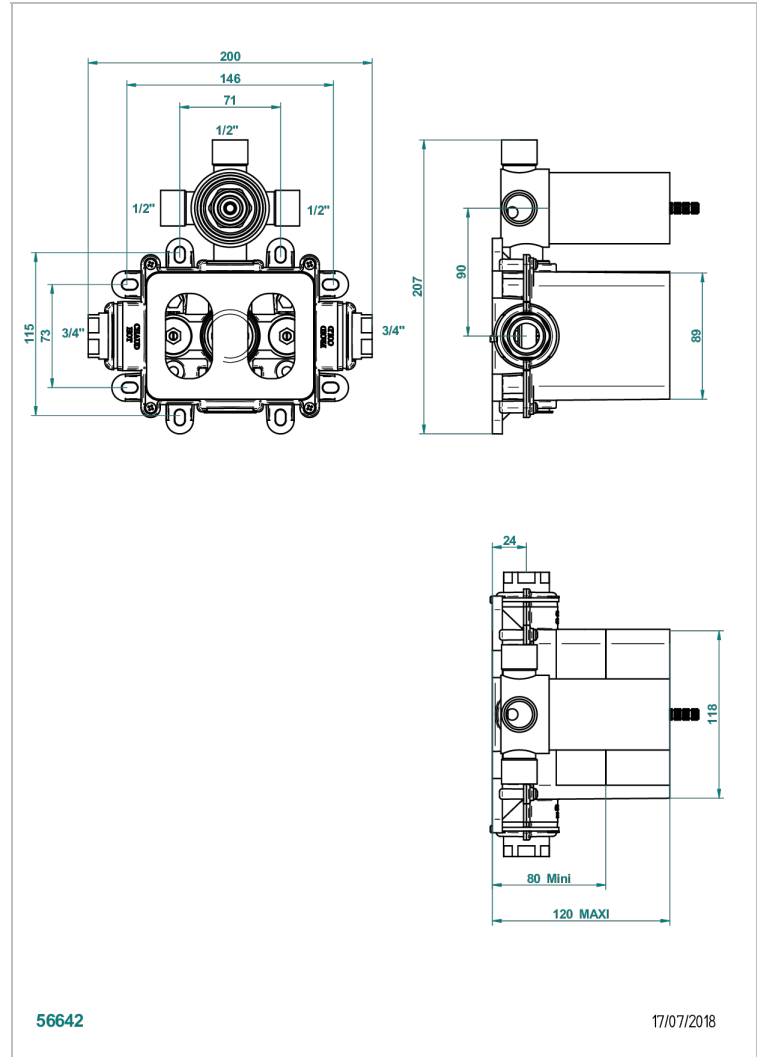

56642

17/07/2018

CHARACTERISTIC

- Brass body
- Encased with protective cover and recessed box
- Ceramic diverter with 3 no 1/2" outputs and stop functions between each output - Ref. 2505/T
- Thermostatic cartridge with wax element - Ref. C5200
- Associated product : thermostatic cover for 5600BE
- ACS : 17ACCLY141
- DVGW : DW-6512CQ0608
- NF : NF EN 1111 - IB - Brut
- SVGW-SSIGE : 1802-6724

TECHNICAL SPECS

- Recommandé : 3 bars (max. 5 bars) - Advised : 43,5 psi (max. 72 psi)
- 34 l/min à 3 bars (9 gpm at 43.5 psi)

STANDARDS



AVAILABLE FINITIONS

*** - A00