

GENERAL PRODUCTS

G00-5200AE/US

3/4" THG thermostat, 60 l/min with wax cartridge, delivered with a built-in box, no trim

THG[®]
PARIS

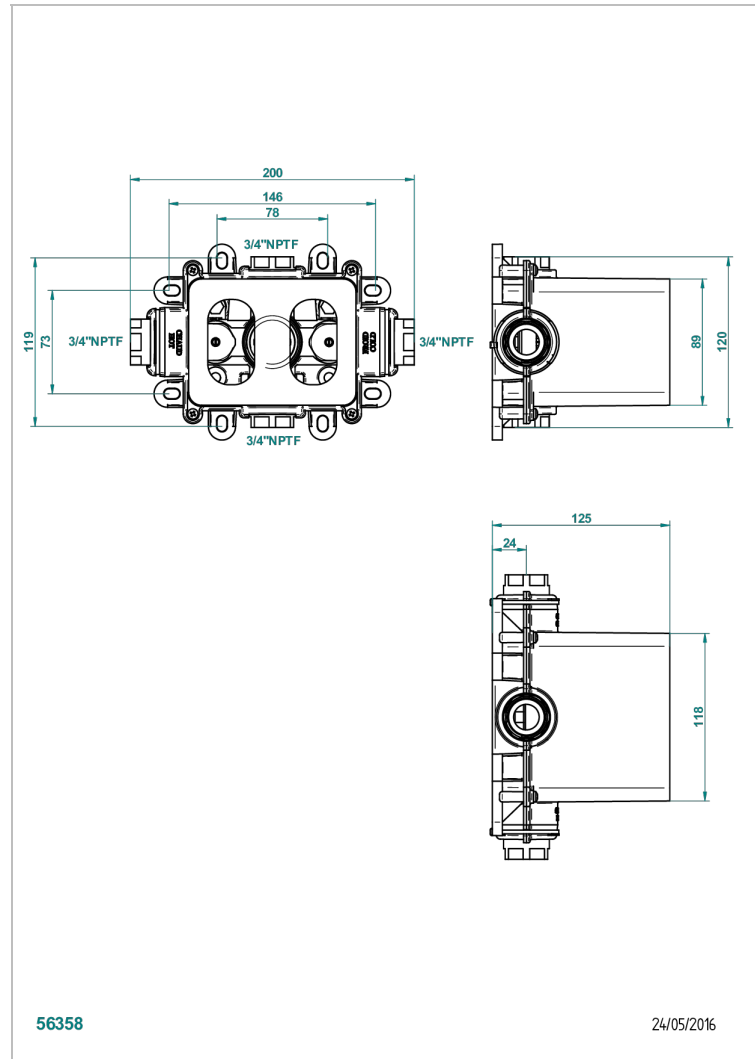

56358

24/05/2016

CHARACTERISTIC

- Solid brass body
- Delivered with built-in box
- Thermostatic wax cartridge - Ref. C5200
- Associated product: thermostatic cover plate and on/off valves ref: 5100B, 5100BR
- On/off valves (or diverter with stop function) required for each shower function
- ASME : ASME A112.18.1-2011/CSA B125.1-11

STANDARDS



RELATED SKU'S

- Ref. G00-5100C Extention kit for thermostatic mixing valve - for installation between 80 mm and 125 mm
- Ref. G00-5100G Reinforced stop ring for THG thermostatic with fixing set

AVAILABLE FINITIONS

*** - A00