

THG[®]

PARIS

MELANGEUR BAIN DOUCHE 4 TROUS SUR GORGE AVEC BEC A INVERSION AVEC COTE 3/4 RIM MOUNTED 4 HOLE BATH/SHOWER MIXER, DIVERTER SPOUT



Référence commerciale pour tête céramique
Sales reference for ceramic head :

4134/2CD: coté 3/4 tête céramique – fermeture à droite

Rim mounted 3/4" ceramic head 1/4 turn right.

Référence commerciale/ sale reference

**112BG : MELANGEUR BAIN DOUCHE 4 TROUS SUR GORGE AVEC
BEC A INVERSION AVEC COTE 3/4**

RIM MOUNTED 4 HOLE BATH/SHOWER MIXER, DIVERTER.

DEBITS

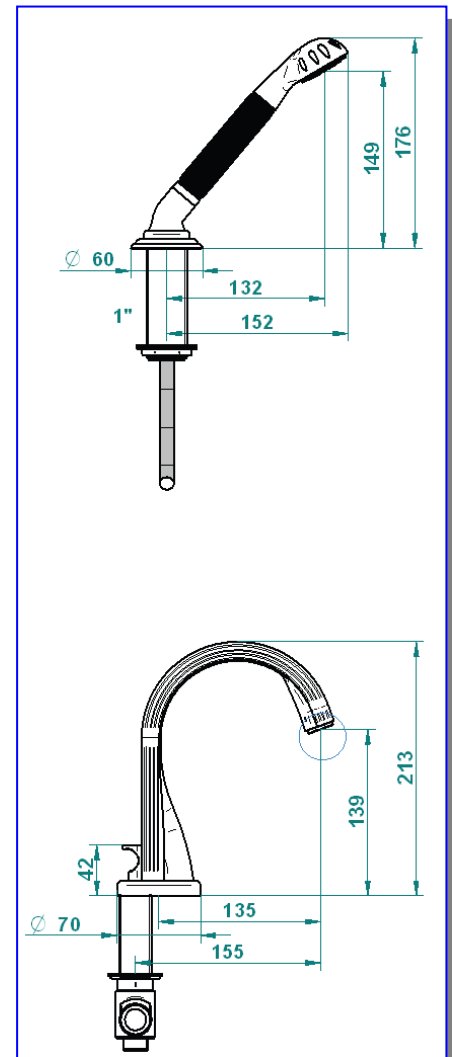
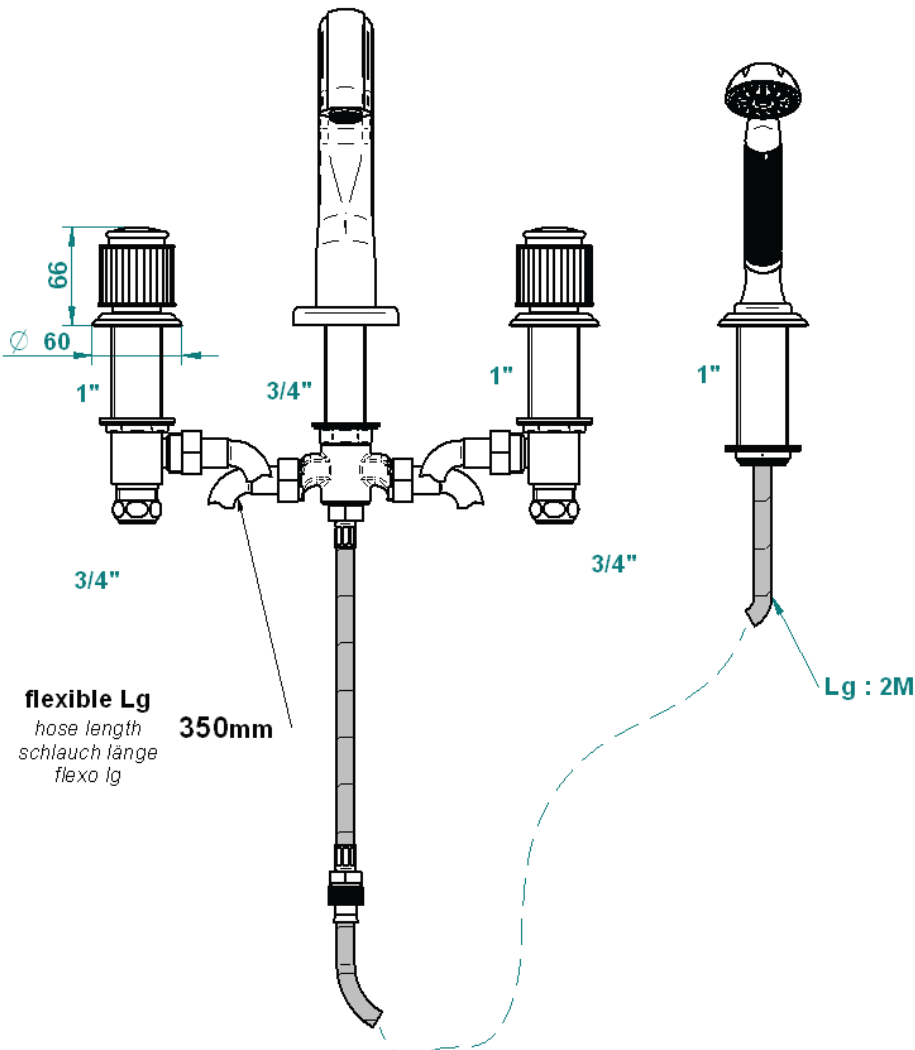
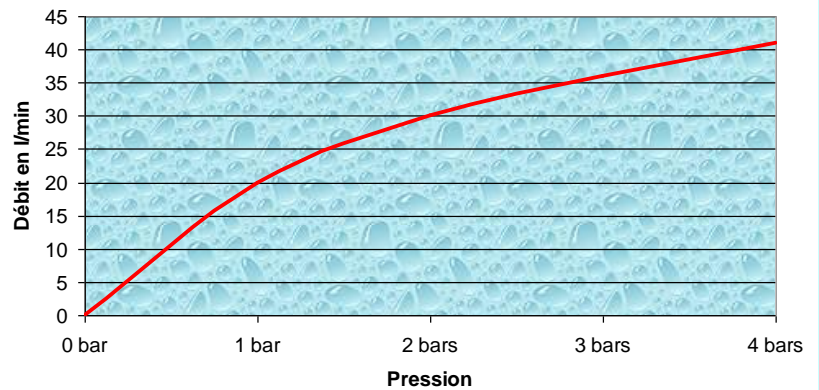

ø de perçage conseillé

recommended drilling ø
empfohlener abstand
Ø de perforación aconsejado

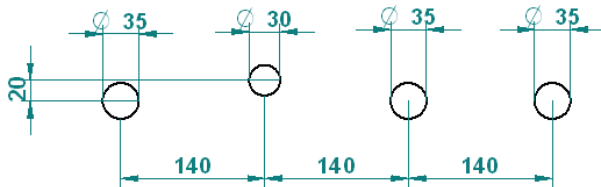

entraxe conseillé

recommended interval width
empfohlener abstand
distancia entre taladros aconsejado

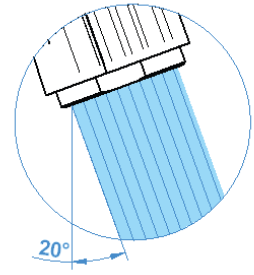
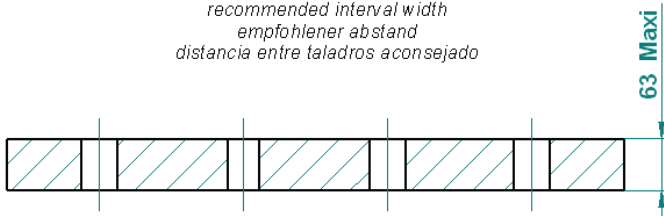

Le diamètre de perçage de tous les éléments est de 35 mm, sauf le bec 30 mm. La distance conseillée entre les centres et les différents éléments est de 140 mm (possibilité de diminuer cette distance entre les centres parce que les éléments sont indépendants).

The diameter of boring for all the elements is of 35mm except the spout 30mm. The advised distance between centers and the different elements is of 140mm (possibility of decreasing this distance between centers because the elements are independent).



- 1) Dévisser la rosace en maintenant le croisillon
Unscrew the flange by maintaining the handle



- 2) Positionner le coté
Position the rim mounted valve.



- 3) Revisser la rosace en maintenant le croisillon
Screw the flange by maintaining the handle



- 4) Bloquer l'écrou
Overtighten the



- 5) Retirez le bouchon, la partie en plastique, l'écrou et la rondelle noire.

Visser la rosace jusqu'en butée.

Remove the cap, the plastic part, the nut and the black washer

Screw the flange until abutment.

- 6) Positionner l'ensemble sur la baignoire
Put the part on the tub rim





7 Mettez le joint noir et visser l'écrou
Put the black washer, screw the nut.



8 Passer le flexible inox dans le coulant par le dessous (partie male vers le haut) et visser le flexible de douche sur le flexible inox.

Put the stainless steel hose in the slide part on the bottom (male side on the top) and screw the handshower hose with the stainless steel hose.



9 Emboîter la douille plastique sur le flexible de douche.
Put the plastic piece on the hose

10 Descendre la pièce plastique dans le coulant sans engager l'écrou conique du flexible.

Slide the plastic piece in the metal part without insert the conical nut

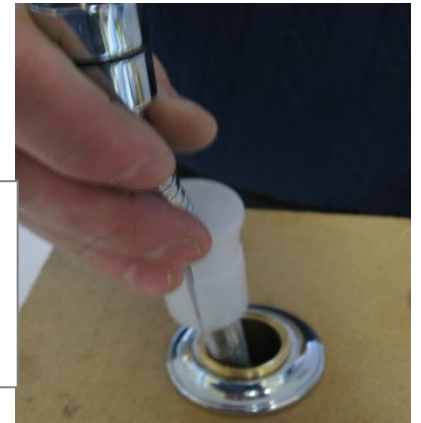

11 Revisser la calotte
Screw the cap again

12 Visser la douche sur le flexible
Screw the hand shower on the hose



13 Relier le flexible inox à la batterie bain ou inverseur ou mitigeur (arrivée d'eau de votre système).

Connect the flexible stainless steel on the bath battery or inverter or mixer (water inlet of your system).



Les conditions générales de garantie, le nettoyage et l'entretien de la robinetterie apparaissent dans les conditions générales de vente.

The warranty policy, cleaning and maintenance of the valves appear in the general conditions of sale.

Robinetterie & Accessoires

35, rue Tourniere - BP 80212 - Béthencourt sur Mer - 80535 Friville cedex - France
www.thg.fr - Tél. +33 (0)3 22 60 20 80 - Fax +33 (0)3 22 26 41 01