

MANDARINE METAL

U1A-13B/US

Exposed tub filler with cradle handshower, wall mounted

THG[®]
PARIS

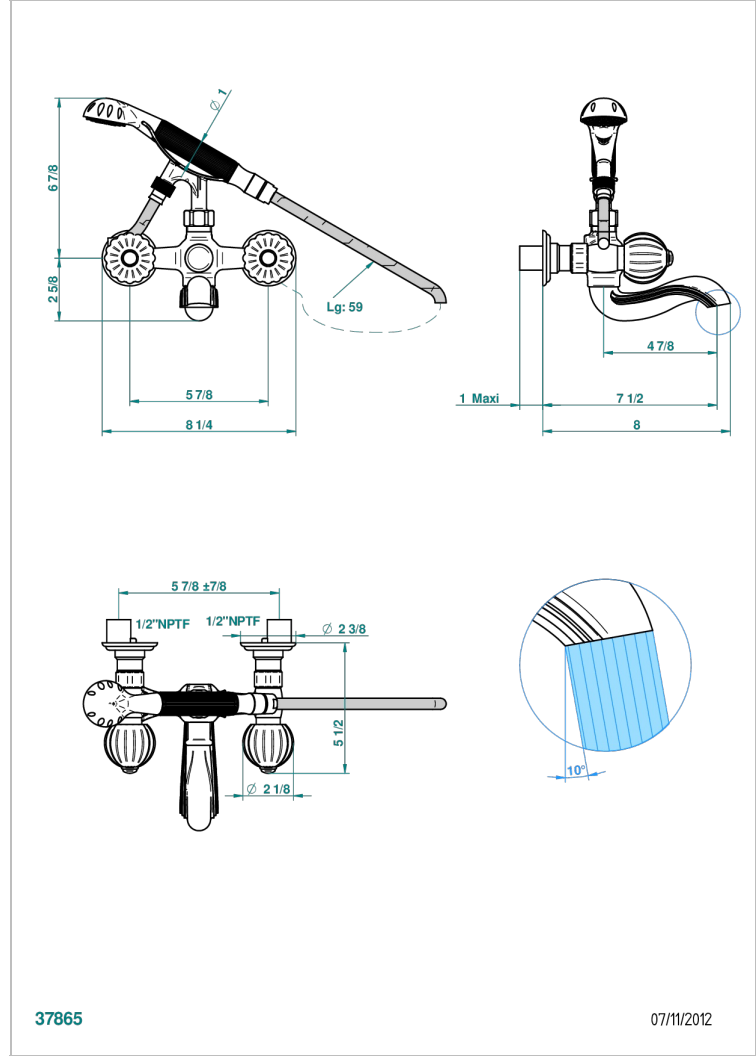

37865

07/11/2012

CARACTERÍSTICAS

- ASME : ASME A112.18.1-2011/CSA B125.1-11

ESPECIFICACIONES TÉCNICAS

- Recommandé : 3 bars (max. 5 bars) - Advised : 43,5 psi (max. 72 psi)
- Bec : 75 l/min à 3 bars - Douchette : 9,5 l/min à 3 bars
- Spout : 19,8 gpm at 43.5 psi - Handshower : 2.5 gpm at 43.5 psi

ESTÁNDAR



ACABADOS DISPONIBLES

Bronce claro - D01
Cerámica negra mate - D30
Cobre viejo mate - H07
Cromo - A02
Cromo / dorado - G02
Cromo mate - C02

Dorado - F01
Dorado mate - F07
Dorado pálido - F30
Dorado pálido mate (sin barniz) - F31
Níquel - B01
Níquel mate - C01

Níquel viejo - H28
Pvd blush - H62
Pvd blush mate - H60
Pvd color latón - H49
Pvd color latón mate - H50
Pvd color níquel - H55

Pvd color níquel mate - H56
Pvd color oro - H52
Pvd color oro mate - H53
Pvd grafito - H64
Pvd grafito mate - H65
Pvd marrón bronce - F33

Pvd marrón bronce mate - F34
Pvd umber - H66
Pvd umber mate - H67