

VIDAGE DE BAIGNOIRE BATH WASTE

Référence commerciale / sale reference:

00302 : Vidage de baignoire réglable hauteur mini 165mm maxi 390 mm avancée mini 110mm maxi 230 mm sortie Ø 40mm - modèle Geberit europeen 150.601.001- livré avec volant de style

Geberit bath waste- European model – Big size – ajustable – height : mini 165 mm – maxi 390 mm Ajustable projection : mini 110 mm – maxi 230 mm – outlet Ø 40 mm – with stylized knob – spirit with lever – automatic bath waste

Débit d'écoulement de la bonde / *flow rate plug* : 48l/mn

Débit trop plein / *overflow flow rate* : 36l/mn

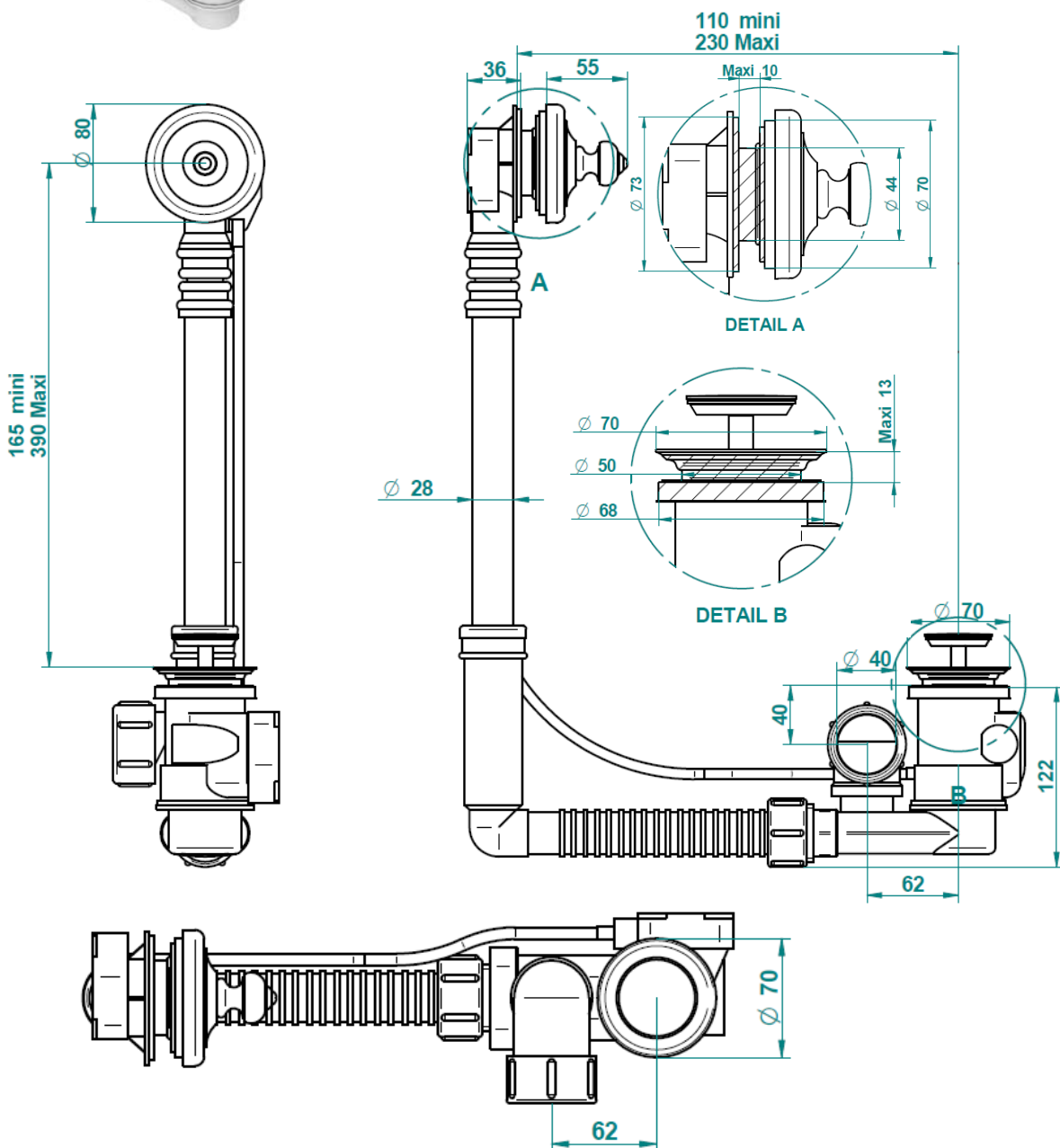

Installation

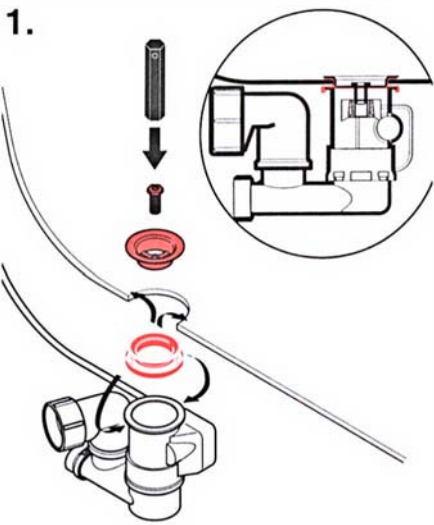
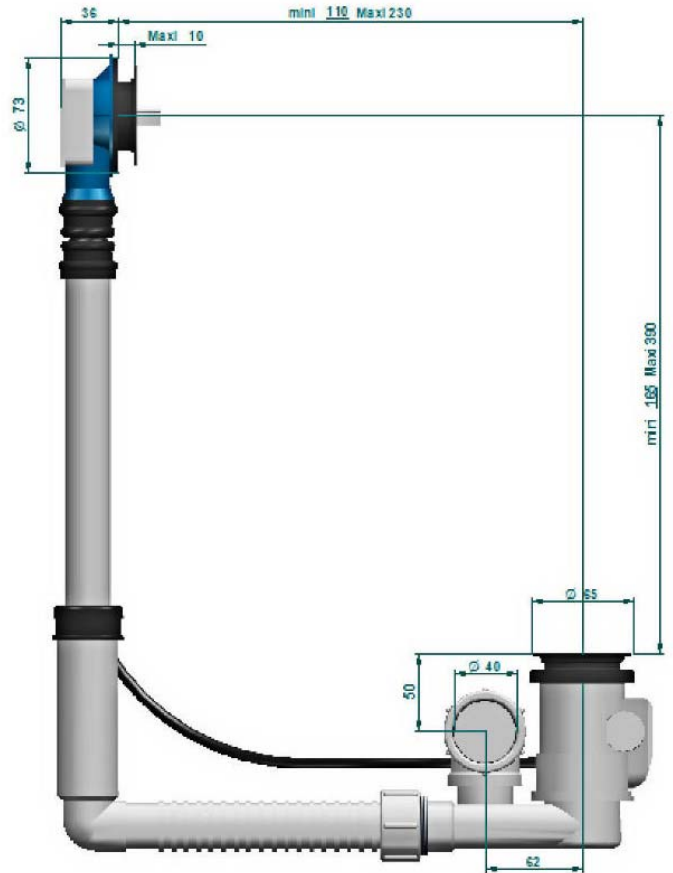
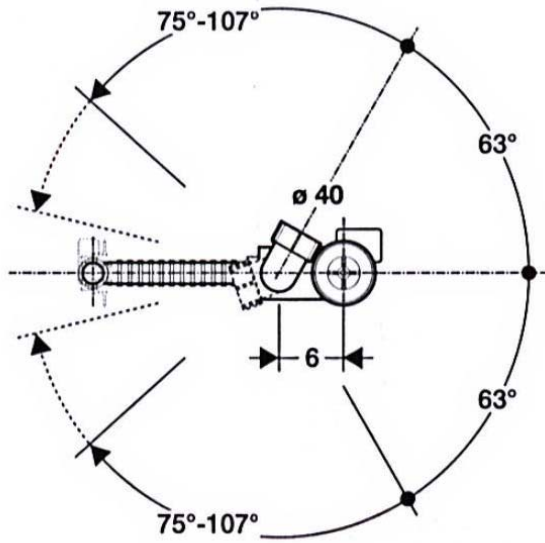

Mettre la partie vidage en position, mettre en place le joint d'étanchéité.

Put the waste in position – Place the seal

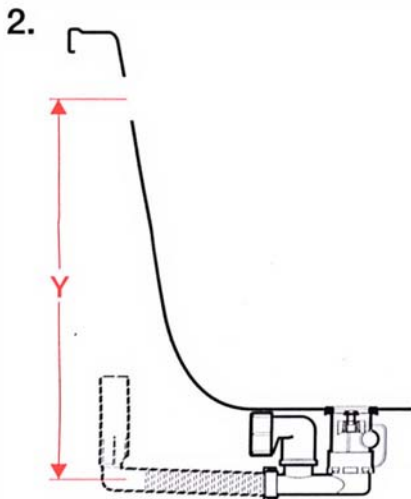

Mesurer la côte Y.
Recouper le tube de la partie trop plein (3cm plus court que la dimension mesurée), ébavurer, remettre le tube en position.

*Measure the Y side.
Trim the overflow tube, deburr and put the tube to position.*

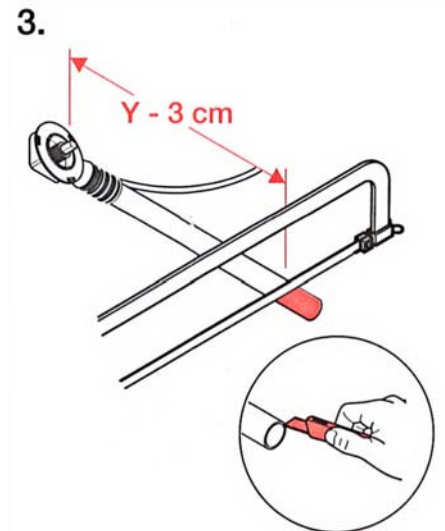

4.

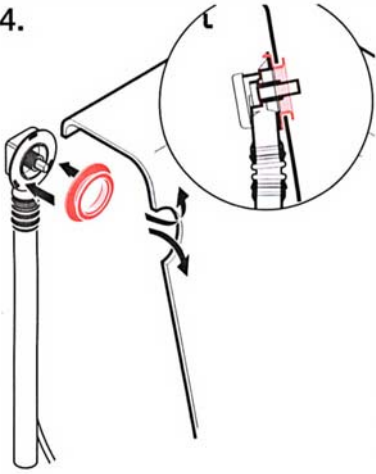

Mettre le joint en position, attention de bien positionner les ergots.

Put the seal in position, be careful to position the pins

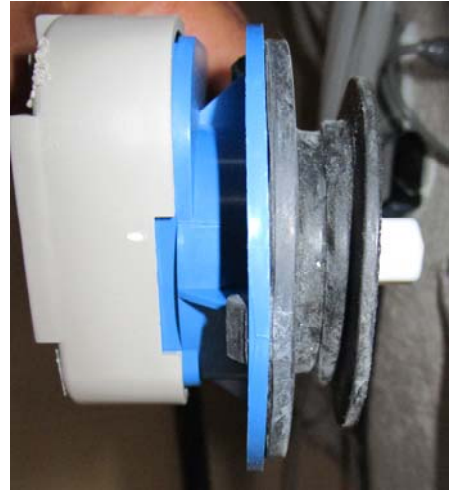

5.

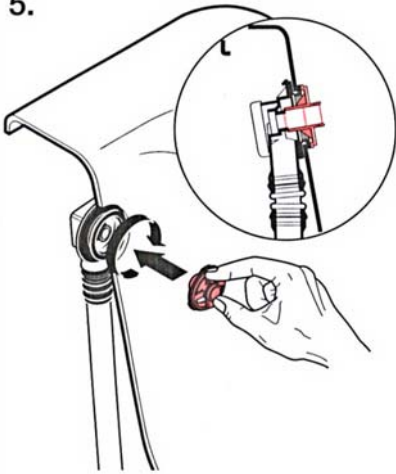

Mettre l'ensemble en position, joint à l'intérieur de la baignoire. En maintenant à l'arrière pour que le joint soit centré par rapport au trou, visser la pièce chromée de serrage, mettre le volant en position et serrer la vis de serrage.

Put the assembly in position, seal inside the bathtub. screw chrome workpiece clamping by maintaining at the rear so that the joint is centered with respect to the hole. Place the cap and and tighten the clamping screw.



7.

6.

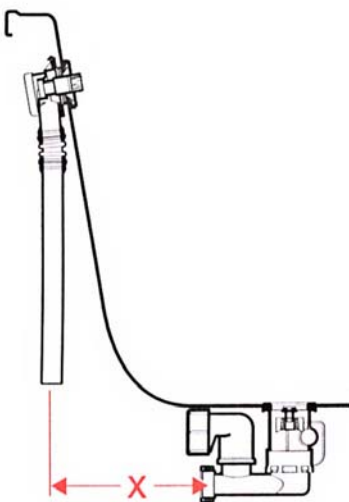

Mesurer la côte X.
Recouper le tube, ébavurer, remettre le tube en position.
Mettre un peu de graisse (fournie) pour remonter la partie haute.

*Measure the X side.
Trim the tube, deburr and put the tube to position.*

Put some grease (supplied) to assembly the upper part.

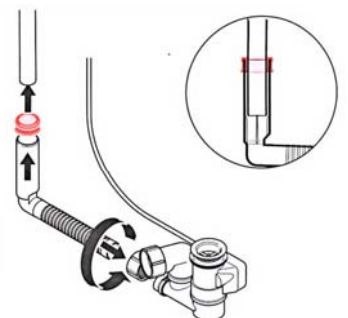
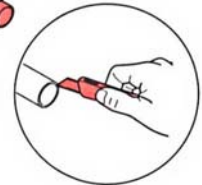
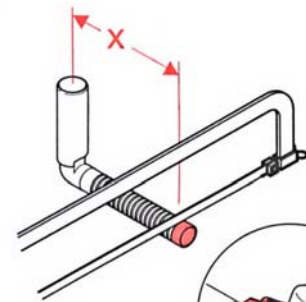

8

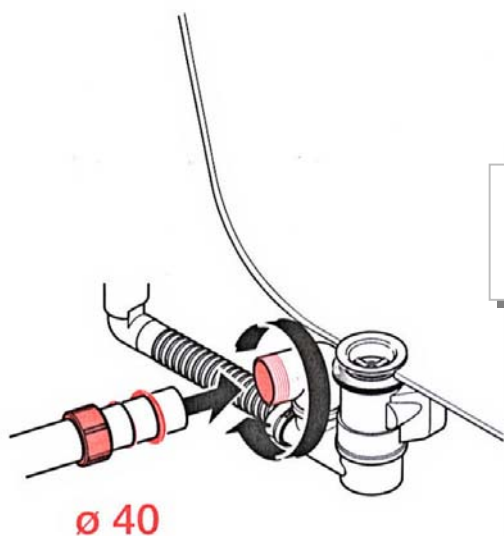

L'évacuation se fait en tube PVC Ø40.

The evacuation is done by a tube PVC Ø40

Les conditions générales de garantie, le nettoyage et l'entretien de la robinetterie apparaissent dans les conditions générales de vente.

The warranty policy, cleaning and maintenance of the valves appear in the general conditions of sale.

Robinetterie & Accessoires

35, rue Tourniere - BP 80212 - Béthencourt sur Mer - 80535 Friville cedex - France
www.thg.fr - Tél. +33 (0)3 22 60 20 80 - Fax +33 (0)3 22 26 41 01