

# MANDARINE METAL

U1A-6532

Rim mounted ceramic mixer with progressive cartridge

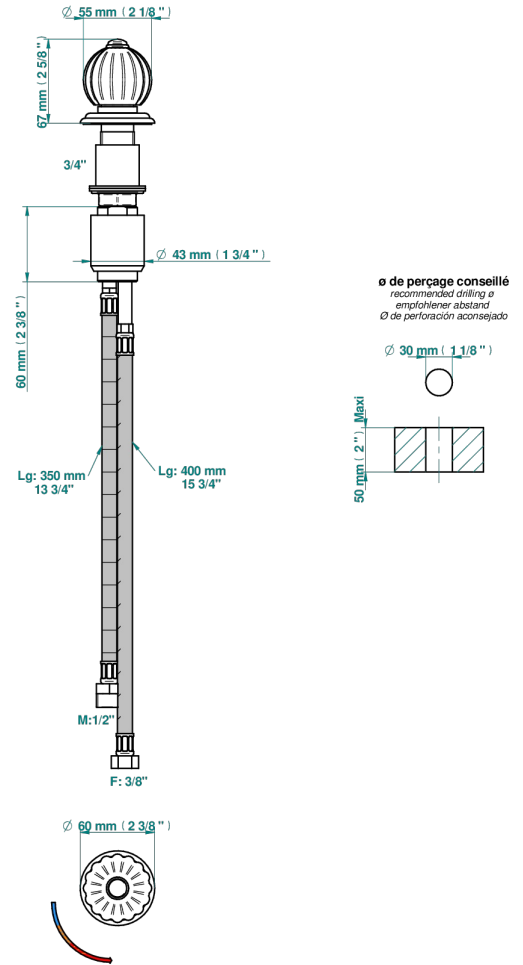

## CHARACTERISTIC

- ACS : 22ACCLY009

## STANDARDS



## AVAILABLE FINITIONS

Black ceram - D30  
Blush PVD - H62  
Brass color PVD - H49  
Brown bronze color PVD - F33  
Chrome polished - A02  
Chrome polished / gold polished - G02

Copper antique matt, coated - H07  
Gold color PVD - H52  
Gold mat - F07  
Gold polished - F01  
Graphite PVD - H64  
Light coated bronze - D01

Matt Umber PVD - H67  
Matt blush PVD - H60  
Matt brass color PVD - H50  
Matt brown bronze color PVD - F34  
Matt chrome (American satin) - C02  
Matt gold color PVD - H53

Matt graphite PVD - H65  
Matt nickel (American satin) - C01  
Matt nickel color PVD - H56  
Nickel antique / Sovereign - H28  
Nickel color PVD - H55  
Nickel polished - B01

Soft gold - F30  
Soft matt gold - F31  
Umber PVD - H66