

# BAMBOU CRISTAL NEGRO

A33-151/US

Rim mounted 3-hole basin mixer with waste

THG<sup>®</sup>  
PARIS

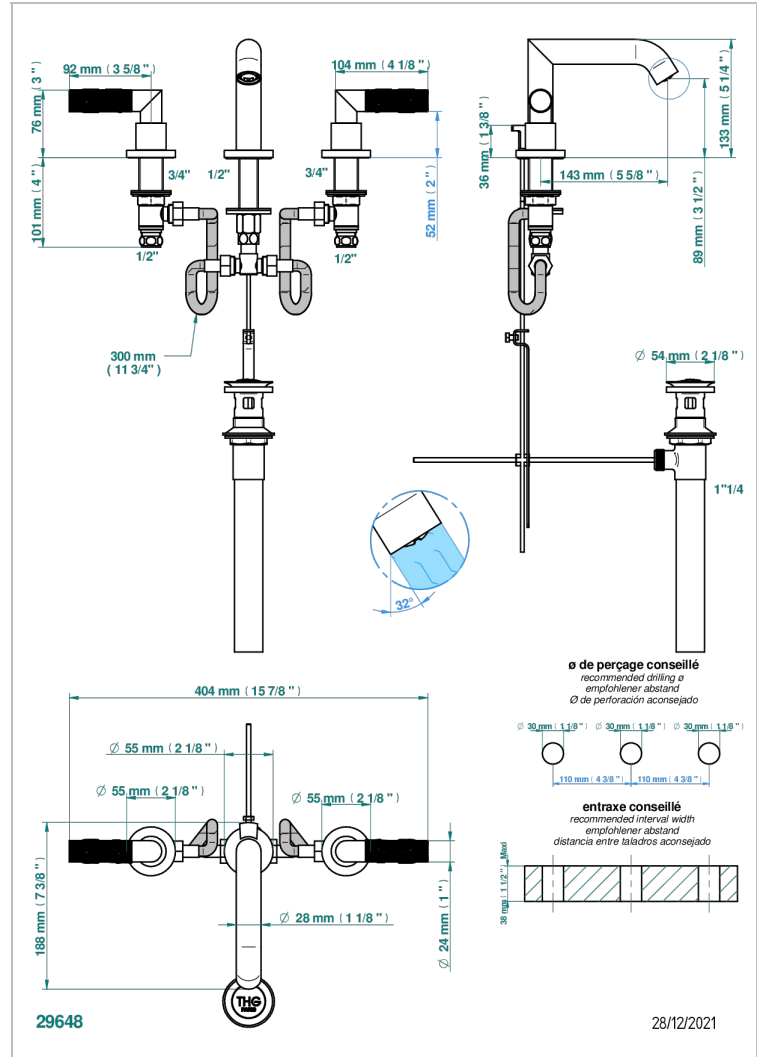

## CARACTERÍSTICAS

- ASME : ASME A112.18.1-2011/CSA B125.1-11

## ESPECIFICACIONES TÉCNICAS

- Recommandé : 3 bars (max. 5 bars) - Advised : 43,5 psi (max. 72 psi)
- 5,7 l/min à 3 bars (1.5 gpm at 43.5 psi)

## ESTÁNDAR



## ACABADOS DISPONIBLES

Bronce claro - D01  
Cerámica negra mate - D30  
Cobre viejo mate - H07  
Cromo - A02  
Cromo / dorado - G02  
Cromo mate - C02

Dorado - F01  
Dorado mate - F07  
Dorado pálido - F30  
Dorado pálido mate (sin barniz) - F31  
Níquel - B01  
Níquel mate - C01

Níquel viejo - H28  
Pvd blush - H62  
Pvd blush mate - H60  
Pvd color latón - H49  
Pvd color latón mate - H50  
Pvd color níquel - H55

Pvd color níquel mate - H56  
Pvd color oro - H52  
Pvd color oro mate - H53  
Pvd grafito - H64  
Pvd grafito mate - H65  
Pvd marrón bronce - F33

Pvd marrón bronce mate - F34  
Pvd umber - H66  
Pvd umber mate - H67