

SULLY LAPIS LAZULI

A1W-151/US

Rim mounted 3-hole basin mixer with waste

THG[®]
PARIS

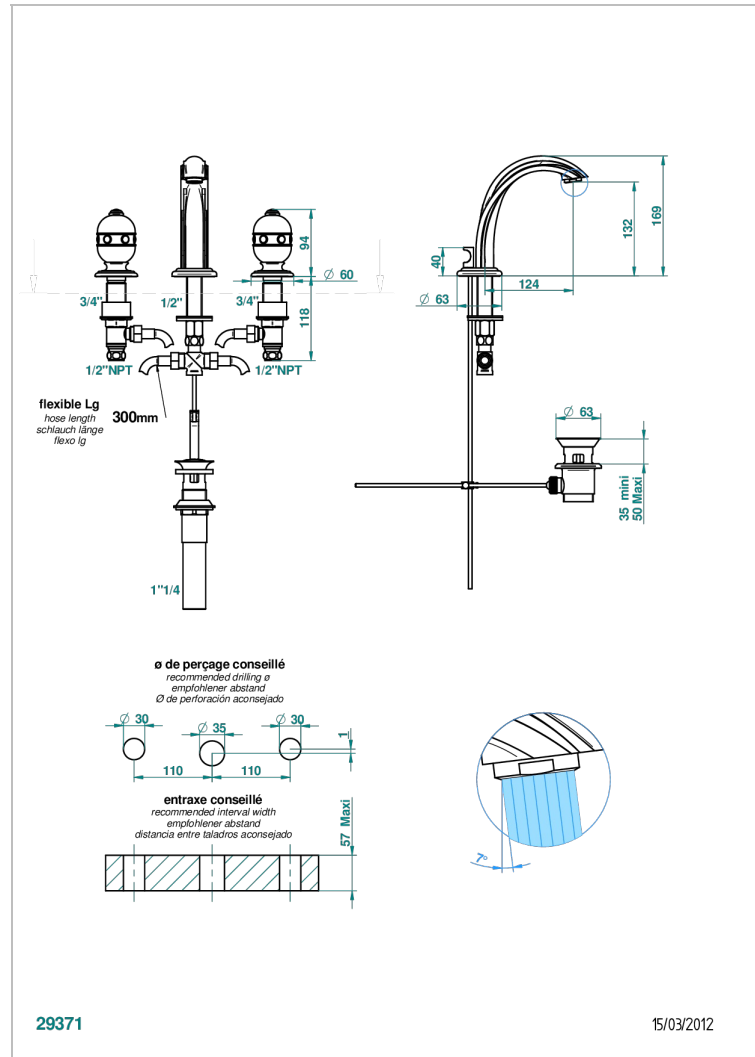

CARACTERÍSTICAS

- ASME : ASME A112.18.1-2011/CSA B125.1-11

ESTÁNDAR



ACABADOS DISPONIBLES

Cerámica negra mate - D30
Cromo - A02
Cromo / dorado - G02
Cromo mate - C02
Dorado - F01
Dorado mate - F07

Dorado pálido - F30
Dorado pálido mate (sin barniz) - F31
Níquel - B01
Níquel mate - C01
Níquel viejo - H28
Pvd blush - H62

Pvd blush mate - H60
Pvd color latón - H49
Pvd color latón mate - H50
Pvd color níquel - H55
Pvd color níquel mate - H56
Pvd color oro - H52

Pvd color oro mate - H53
Pvd grafito - H64
Pvd grafito mate - H65
Pvd marrón bronce - F33
Pvd marrón bronce mate - F34
Pvd umber - H66

Pvd umber mate - H67

ESPECIFICACIONES TÉCNICAS

- Recommandé : 3 bars (max. 5 bars) - Advised : 43,5 psi (max. 72 psi)
- 5,7 l/min à 3 bars (1.5 gpm at 43.5 psi)