

METROPOLIS CLEAR CRYSTAL WITH LEVER

A2B-5100B

Trim for THG thermostat - ref. 5 100A 1/2", 5 200A & 5 200AE 3/4"

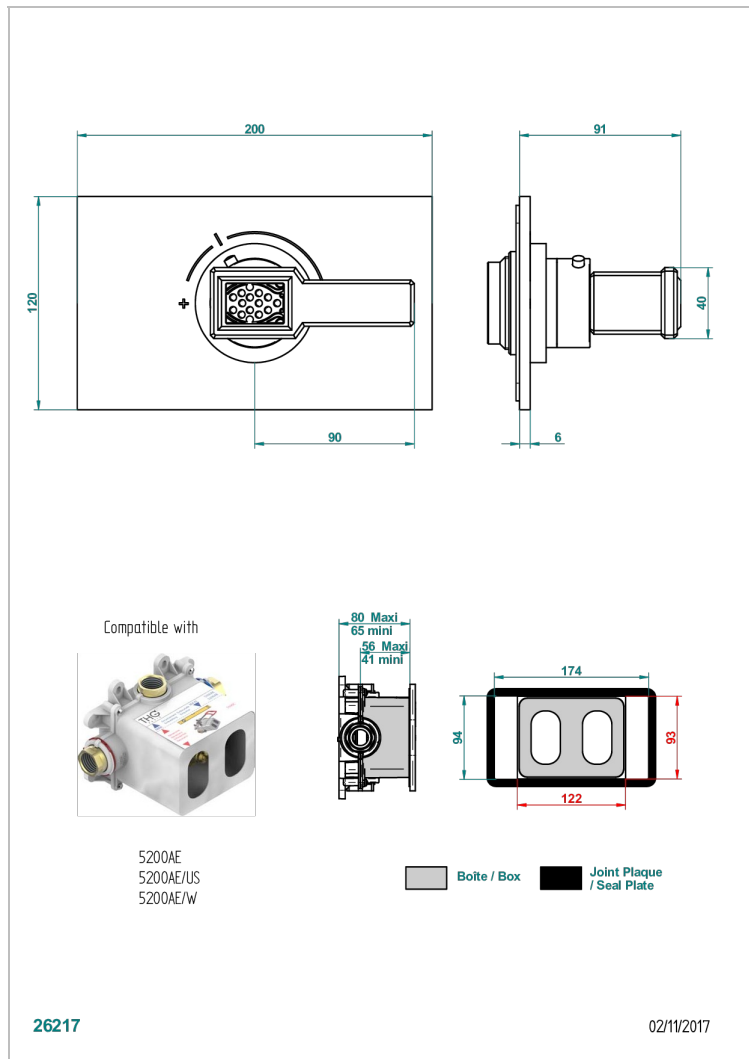
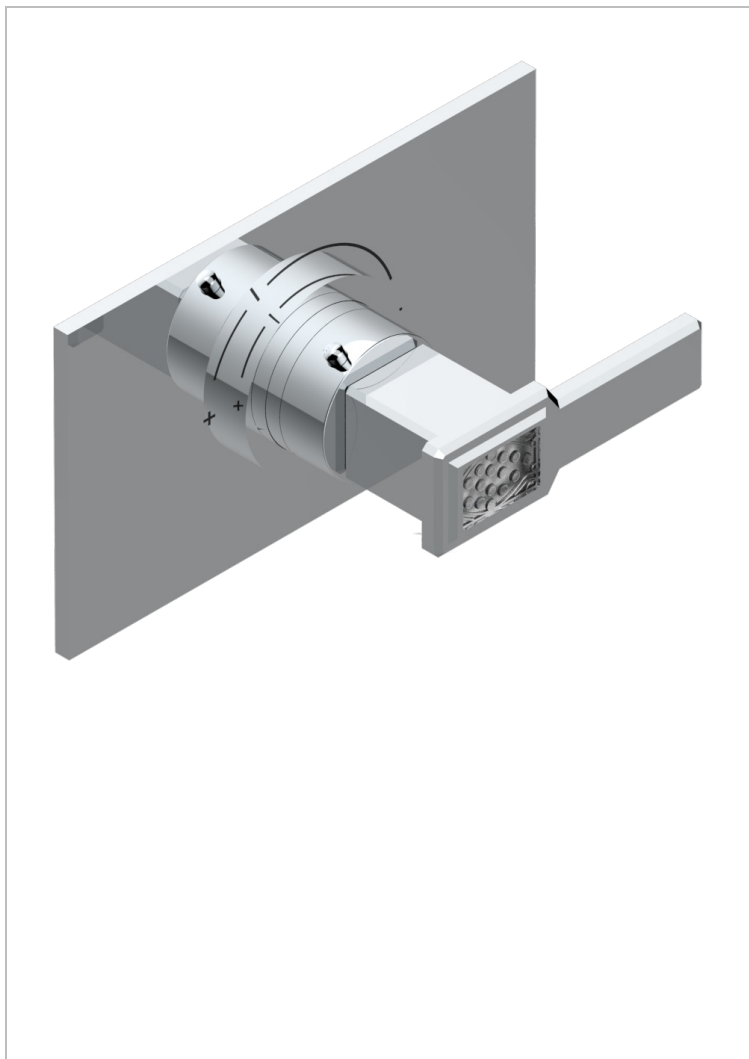

CHARACTERISTIC

- Requires concealed thermostat ref. 5200AE, 5200AE/US and 5200AE/W
- Temperature control knob with security stop at 38°C
- On/off valves (or diverter with stop function) required for each shower function
- Solid brass plate and knob
- ASME : ASME A112.18.1-2011/CSA B125.1-11
- DVGW : DW-6512CQ0608

STANDARDS



RELATED SKU'S

- Ref. G00-5100C Wall connector for THG thermostatic valves , for wall built-in depth between 80 and 125 mm
- Ref. G00-5100G Reinforced stop ring for THG thermostatic with fixing set
- Ref. G00-5200AE 3/4" THG thermostat, 60 l/min with wax cartridge, delivered with a built-in box, no trim

AVAILABLE FINITIONS

Antique nickel - H28
Black ceram - D30
Blush PVD - H62
Brass color PVD - H49
Brown bronze color PVD - F33
Gold color PVD - H52

Graphite PVD - H64
Matt Umber PVD - H67
Matt blush PVD - H60
Matt brass color PVD - H50
Matt brown bronze color PVD - F34
Matt chrome - C02

Matt gold - F07
Matt gold color PVD - H53
Matt graphite PVD - H65
Matt nickel (color finish) - C01
Matt nickel color PVD - H56
Nickel color PVD - H55

Polished chrome (color finish) - A02
Polished chrome / Polished gold (color finish) - G02
Polished gold (color finish) - F01
Polished nickel - B01
Soft gold - F30
Soft matt gold - F31
Umber PVD - H66