

# MANDARINE CLEAR CRYSTAL

UID-3205/202

THG  
PARIS

单孔坐浴盆龙头，球形联轴节自动分水式升降喷头和下水器

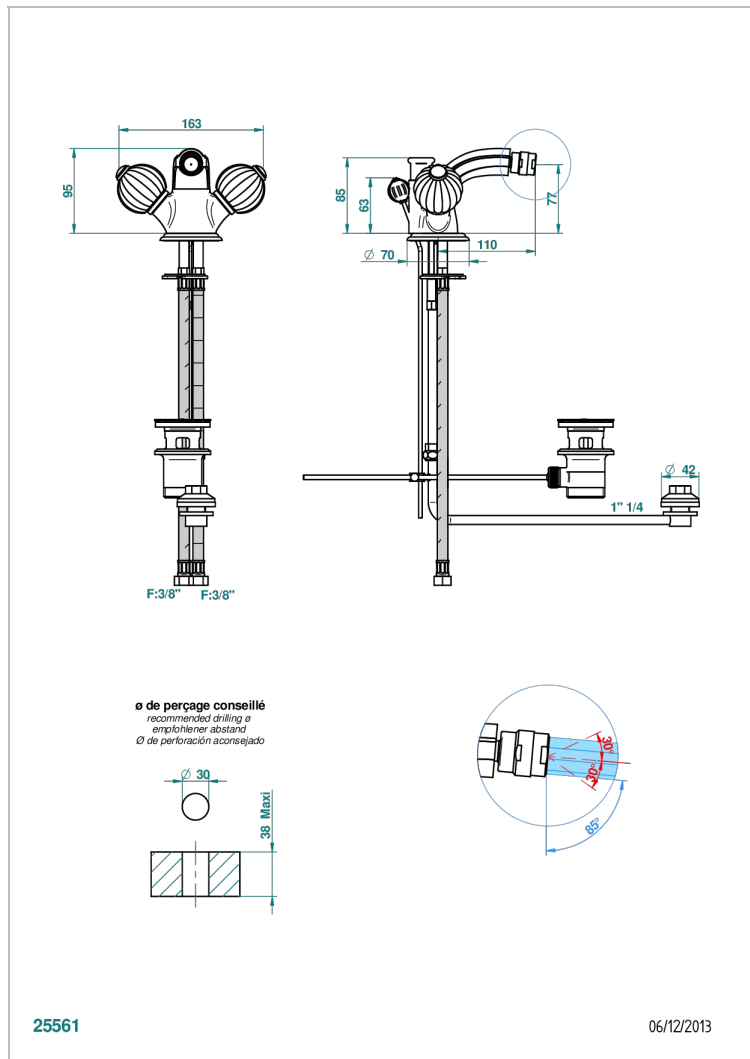

## 特色

- Mandarin Clear crystal
- 单孔坐浴盆龙头，球形联轴节自动分水式升降喷头和下水器

## 技术特征

- Recommandé : 3 bars (max. 5 bars) - Advised : 43,5 psi (max. 72 psi)
- 15 l/min à 3 bars (4 gpm at 43.5 psi)

## 可选饰面

Black ceram - D30  
Blush PVD - H62  
Graphite PVD - H64  
Matt Umber PVD - H67  
Matt blush PVD - H60  
Matt graphite PVD - H65

PVD哑光棕铜 - F34  
PVD哑光金 - H53  
PVD哑光铜 - H50  
PVD哑光镍 - H56  
PVD抛光铜 - H49  
PVD棕铜 - F33

PVD金色 - H52  
PVD镍 - H55  
Umber PVD - H66  
哑光复古铜 - H07  
哑光浅金 - F31  
哑光金 - F07

哑光铬 - C02  
哑光镍 - C01  
复古镍 - H28  
抛光金 (24K金) - F01  
抛光铬 - A02  
抛光铬/抛光金 - G02

抛光镍 - B01  
浅金 - F30  
漆面铜 - D01