

# AMOUR DE TRIANON

G24-64

Mélangeur de douche 1/2", entraxe 150 mm (+ ou- 22)

THG<sup>®</sup>  
PARIS

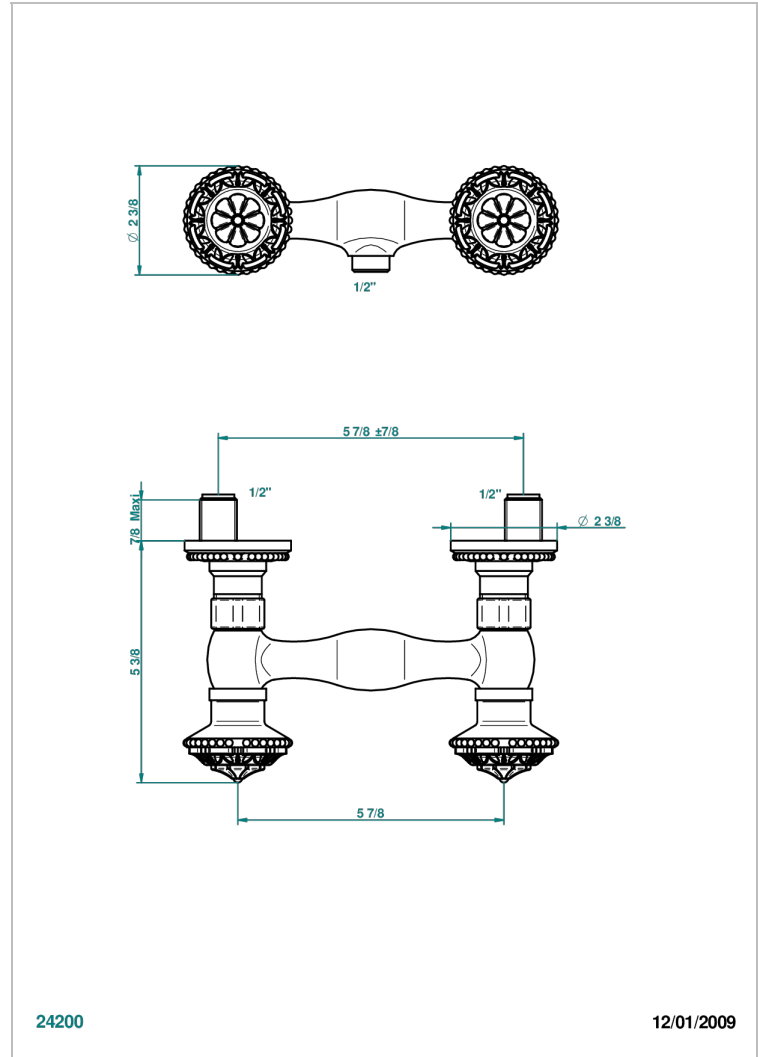

## CARACTÉRISTIQUES

- ACS : 17ACCLY652
- NF : NF EN 200 - IA - Chrome

## CERTIFICATIONS



## FINITIONS DISPONIBLES

Bronze clair - D01  
Chromé - A02  
Chromé / doré - G02  
Chromé mat - C02  
Doré brillant - F01  
Doré mat - F07

Nickel brillant - B01  
Nickel mat - C01  
Noir mat céramique - D30  
Or pâle - F30  
Or pâle mat - F31  
Vieux cuivre rouge mat - H07

Vieux nickel - H28