

LE CŒUR DE

---

COLLECTIONS

THG<sup>®</sup>  
P A R I S



# THG<sup>®</sup>

P A R I S

---

Fondée en 1956, THG Paris est spécialisée dans la conception, la fabrication et la commercialisation de robinetteries et accessoires de salles de bain haut de gamme.

Présente dans plus de 60 pays, THG Paris est une société de dimension internationale. Forte de 6 filiales à Londres, Paris, Moscou, New York, Shanghai et Dubaï, elle assure partout dans le monde un accompagnement sur-mesure.

Sa maîtrise complète du process de conception et de production en interne lui permet d'offrir des solutions et designs innovants. Ainsi, elle collabore régulièrement avec des designers renommés tels Jamie Drake, Gilles & Boissier, Martin Kemp, Charles Zana, etc.

Basés près des côtes de Normandie, ses ateliers concentrent l'ensemble des savoir-faire. Cette maîtrise est reconnue par le label EPV, gageure de l'excellence française. Un haut niveau d'exigence partagé par plusieurs partenaires comme Lalique, Baccarat, Christofle ou encore Haviland.

Soucieux d'offrir des solutions complètes et coordonnées, tant dans les designs que les finitions, THG Paris élargit son offre au fil des années et propose des produits complémentaires : la robinetterie de cuisine, les produits électroniques, les sèche-serviettes ou les poignées de porte.



David Bonnelle  
CEO THG Paris

---

Founded in 1956, THG Paris are specialists in the design and manufacturing of ornate luxury brassware and accessories.

Spanning 60 countries, with subsidiaries in London, Paris, Moscow, New York, Shanghai and Dubai, THG Paris can manage projects globally and offer a bespoke service to its clients. By mastering all processes from conception to production, THG Paris can offer innovative and turn-key solutions.

This is complemented by our extensive collaborations with renowned designers including Jamie Drake, Gilles & Boissier, Martin Kemp and Charles Zana to name a few.

Based along the Normandie coastline, our factory utilises local resources and our employee's expansive knowledge to manufacture luxury brassware in one place, culminating in recognition from French label EPV. Long-standing relationships with partner companies such as Lalique, Baccarat, Christofle and Haviland have enabled THG Paris to offer a vast array of brassware solutions with their respective coordinated accessories and finishes throughout some of the extravagant residential and commercial projects in the world. In recent times,

THG Paris has expanded their library by offering complementary products ranging from Kitchenware, electronic solutions, heated towel rails and door handles.



## UN SAVOIR-FAIRE UNIQUE - UNE PORTÉE INTERNATIONALE UNIQUE KNOW-HOW AND INTERNATIONAL SCOPE

Artisan ou industriel ? THG Paris n'a jamais voulu choisir. Grâce à son savoir-faire unique, elle propose des produits d'exception, maîtrisant dans ses ateliers tous les stades de la fabrication, du dessin à la fonderie en passant par l'usinage jusqu'aux finitions.

Depuis 2011, son savoir-faire est reconnu par l'attribution du prestigieux label Entreprise du Patrimoine Vivant (EPV), une marque de reconnaissance de l'État mise en place pour distinguer des entreprises françaises aux savoir-faire artisanaux et industriels d'excellence.

Précurseur sur le marché de la robinetterie haut de gamme, THG Paris s'est construit une forte réputation à l'international. Une portée qui lui vaut d'être sollicitée par des établissements prestigieux, à l'image des hôtels Four Seasons George V à Paris, The Dorchester à Londres, 1010 Park Avenue à New York ou encore le Grand Hyatt Hotel à Dubaï.

En parallèle, l'entreprise a su imposer sa présence par l'ouverture de showrooms dans les plus grandes villes du monde telles que Londres, Paris, New York, Dubaï ou Shanghai. THG Paris est aujourd'hui présente dans plus de 60 pays.

Combining both elite craftsmanship and innovative industrial practices, THG Paris is able to provide exceptional products. Our craftsmen, each with unique specialisations, have mastered every facet of manufacturing our products from initial design to machining and finishing. Since 2011, THG Paris has been recognised by the prestigious EPV label, an accolade awarded only to companies who display excellence in crafting their products.

THG Paris has built its reputation across the world for our pioneering approach to high-end brassware. A reputation that has culminated in being trusted to specify prestigious projects such as the Four Seasons George V in Paris, The Dorchester in London, 1010 Park Avenue in New York and the Grand Hyatt in Dubai to name a few.

Developing our global reach for over 60 years, THG Paris is now cemented as a global brand, servicing 60 countries and opening showrooms in cities synonymous with design including, Paris, London, New York, Dubai and Shanghai.



## DES PARTENAIRES ET DESIGNERS D'EXCEPTION THG PARIS, A STORY OF EXCEPTIONAL PARTNERSHIPS

*Baccarat*

*Daum*  
FRANCE 1878

LALIQUE

BERNARDAUD

*Christofle*  
PARIS

HAVILAND  
LIMOGES FRANCE 1842

  
Manufacture de Monaco  
MANUFACTURE  
DE MONACO

Novateur, à l'écoute de sa clientèle et toujours à l'avant-garde des tendances, THG Paris s'entoure des meilleurs. Quel que soit le projet, l'entreprise visera l'excellence.

THG Paris a fait appel aux plus prestigieuses Maisons de luxe françaises, de la cristallerie à la porcelaine en passant par l'orfèvrerie pour réaliser des pièces d'exception.

THG Paris s'est entouré de designers de renommée internationale pour concevoir des collections uniques. Chacun avec leur style et leur vision du design, ils ont créé des collections uniques.

As a trend setter and always ahead of its time, THG Paris surrounds itself by the best. Whatever the project, the company aims towards excellence.

To this endeavour, it has sought the partnership of the most prestigious French luxury Maisons, from crystal and porcelain makers to goldsmiths to create exceptional pieces.

THG Paris has also surrounded itself with internationally renowned designers to conceive unique designs, each with their style and vision.

REMI  
TESSIER  
DESIGN

*PR*  
PIERRE-YVES ROCHON

CharlesZana

**C**  
xavier cartron  
PARIS

PINTO

STUDIO PUTMAN

  
JAMIE DRAKE

GILLES & BOISSIER

  
TIMOTHY  
CORRIGAN

**MK**  
MARTIN KEMP DESIGN

CHAMPALIMAUD

**O.**  
ogossart

STUDIO F·A·PORSCHE

**SC**  
SC Esthétique  
1978

**ARIK LEVY**  
ART&DESIGN STUDIO



© Prince de Galles / Suite Lallique by Patrick Hellmann • Crédit photos : Eric Laignel



UNE OFFRE COMPLÈTE POUR VOTRE SALLE DE BAIN  
A COMPLETE PACKAGE FOR YOUR BATHROOM



**LAVABO**  
BASIN



**ACCESSOIRES**  
ACCESSORIES

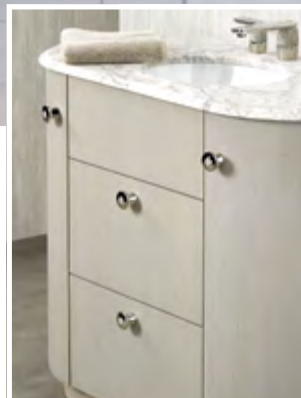

**BOUTONS ET**  
**MEUBLES**  
KNOBS AND  
FURNITURES

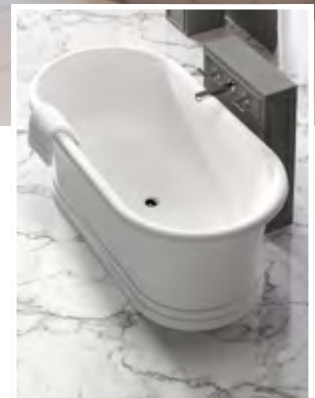

**SANITAIRE**  
SANITARYWARE



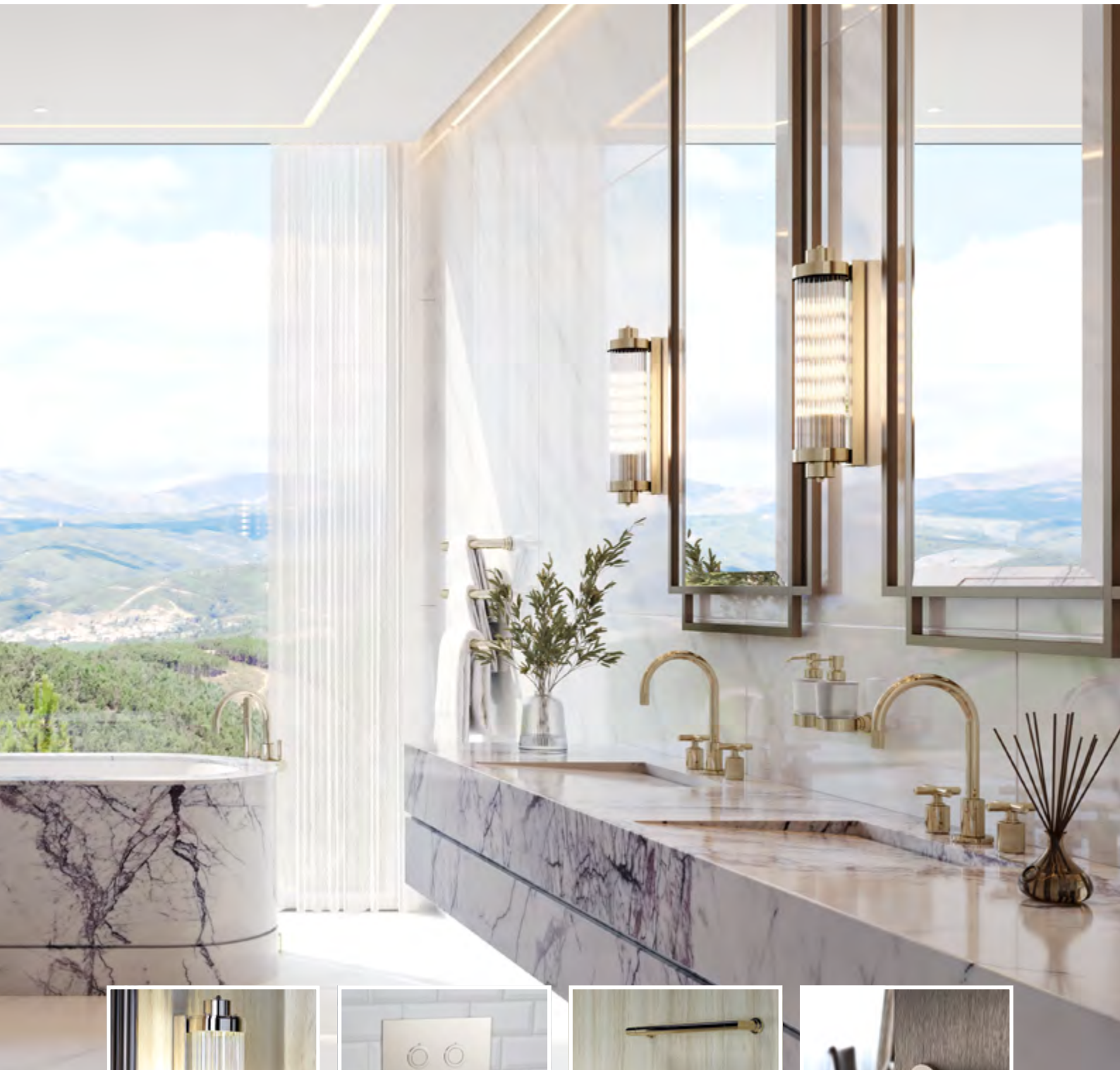

**APPLIQUES  
SCONCES**

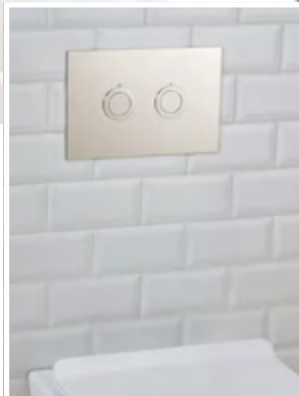

**PLAQUES ET  
ACCESSOIRES WC  
WC PLATES AND  
ACCESSORIES**

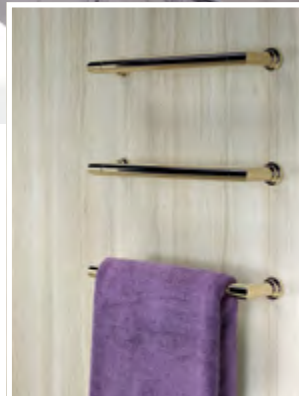

**SÈCHE-SERVIETTES  
TOWEL WARMERS**



**POIGNÉES  
DE PORTES  
DOOR HANDLES**



## UNE DÉMARCHE ENVIRONNEMENTALE ENGAGÉE

### A COMMITTED ENVIRONMENTAL POLICY

Dès 2000, THG Paris s'est engagée en matière de développement durable. Depuis 22 ans, elle s'attache à réduire son empreinte écologique, avec à cœur de concilier au mieux ses savoir-faire et son esprit d'innovation au service d'une durabilité pionnière (et des valeurs responsables).

C'est ainsi que chez THG Paris, on se soucie du moindre impact de chaque objet produit selon une triple martingale : garantir à tous - nos équipes, nos clients, nos fournisseurs, nos designers partenaires - une responsabilité Économique, Environnementale, Sociétale exemplaires.

- Recyclage des matériaux
- Panneaux photovoltaïques
- Eclairage LED
- 80% de l'eau utilisée en production est recyclée

THG Paris made sustainable development one of its core values as early as the year 2000. It has been committed to reducing its environmental footprint, using its spirit of innovation and know-how to become a pioneer in sustainability.

























At THG Paris our concern is with every single aspect of the ecological impact of our products. We have an unparalleled commitment to economically, environmentally, and socially responsible business practices, to the benefit of employees, clients, suppliers and design partners.

- Recycled materials
- Photovoltaic panels
- LED lighting
- 80% recycling of water used in production



CONTEMPORAIN.....	23
<b>ICON-X</b>	<b>25</b>
<b>YOKO</b>	<b>27</b>
<b>SOHO</b>	<b>29</b>
<b>COLLECTION O</b>	<b>31</b>
<b>ANOA</b>	<b>33</b>
<b>NANO</b>	<b>35</b>
<b>LE 11</b>	<b>37</b>
<b>PROFIL</b>	<b>39</b>
<b>BELUGA</b>	<b>41</b>
<b>PURE</b>	<b>43</b>
TRANSITIONNEL.....	45
<b>ESTRELA</b>	<b>47</b>
<b>HAMPTONS</b>	<b>49</b>
<b>LES ONDES</b>	<b>51</b>
<b>GRAND CENTRAL</b>	<b>53</b>
<b>WEST COAST</b>	<b>55</b>
<b>CLUB SAINT-GERMAIN</b>	<b>57</b>
<b>SAINT-GERMAIN</b>	<b>59</b>
<b>BEAUBOURG</b>	<b>61</b>
<b>FAUBOURG PORCELAIN</b>	<b>63</b>
<b>FAUBOURG MÉTAL</b>	<b>65</b>
<b>LE 9</b>	<b>67</b>
<b>SPIRIT</b>	<b>69</b>
<b>DEAN</b>	<b>71</b>
<b>BONDI</b>	<b>73</b>
CLASSIC DESIGN.....	75
<b>SYSTEM</b>	<b>77</b>
<b>MONTAIGNE</b>	<b>79</b>
<b>MÉTAMORPHOSE</b>	<b>81</b>
<b>CORVAIR</b>	<b>83</b>
INTEMPOREL.....	85
<b>JAIPUR</b>	<b>87</b>
<b>MANDARINE</b>	<b>89</b>
<b>NAJEM</b>	<b>91</b>
<b>DIPLOMATE</b>	<b>93</b>
<b>ART DÉCO - TRADITION</b>	<b>95</b>

CHARLESTON	97	SANITAIRE.....	181
1900	99	<b>BAIGNOIRES EN ÎLOT</b>	
BROADWAY	101	FREESTANDING BATHTUBS	183
DUOMO	103	<b>BAIGNOIRES À ENCASTRER</b>	
MALMAISON	105	BUILT-IN BATHTUBS	185
LES BAROQUES	107	<b>VASQUES</b>	
		WASH BASINS	187
PRESTIGE .....	109	<b>VASQUES MÉTAL</b>	
BEYOND CRYSTAL	113	METAL WASH BASINS	189
PÉTALE DE CRISTAL	115	ACCESSOIRES.....	191
HIRONDELLES	119	<b>ACCESSOIRES COORDONNÉS</b>	
MÉTROPOLIS	121	COORDINATED ACCESSORIES	193
MASQUE DE FEMME	123	<b>GÉNÉRIQUES</b>	
ANGE - NAÏADE	125	GENERIC	195
PANTHÈRE	127	<b>MIROIRS</b>	
BAMBOU	129	MIRRORS	197
OCÉANIA - PAPILLON - VENICE	131	<b>WC</b>	<b>199</b>
DAHLIA	133	<b>BECS CASCADE</b>	
PROFIL CRISTAL	135	WATERFALLS	201
MOSSI	137	<b>DOUCHE</b>	
CAMÉLIA	141	SHOWER	203
SUN DRAGON	143	<b>VIDAGES</b>	
ROSE	145	WASTES	205
NEW ISLAND	147	<b>SÈCHE-SERVIETTES</b>	
NEW PARADISE	149	TOWEL WARMERS	207
GINKGO	151	<b>POIGNÉES DE PORTES</b>	
VEGETAL	153	DOOR HANDLES	209
FLORE	155	CUISINE.....	211
INFINI	159	<b>MÉLANGEURS ET MITIGEURS</b>	
NIHAL	161	MIXERS AND SINGLE LEVERS	213
ITHAQUE	163		
MARQUISE	165		
MONTE CARLO	167		
FROUFROU - FRIVOLE	169		
VOGUE	173		
AMBOISE	175		
SULLY - CHEVERNY	177		
TROCADERO	179		

 <p><b>U7G</b> ICON-X</p>	 <p><b>U7H</b> ICON-X à manettes with lever handles</p>	 <p><b>U7J</b> ICON-X insert métal metal inlay</p>	 <p><b>U7K</b> ICON-X insert métal à manettes metal inlay with lever handles</p>	 <p><b>U7L</b> ICON-X insert titane titanium inlay</p>
 <p><b>U7M</b> ICON-X insert titane à manettes titanium inlay with lever handles</p>	 <p><b>U7S</b> ICON-X insert carbone gold carbon gold inlay</p>	 <p><b>U7T</b> ICON-X insert carbone gold à manettes carbon gold inlay with lever handles</p>	 <p><b>G7R</b> YOKO</p>	 <p><b>G7S</b> YOKO COLORS</p>
 <p><b>G7T</b> YOKO ICE</p>	 <p><b>G7U</b> YOKO HOWLITE</p>	 <p><b>G7V</b> YOKO DELTA</p>	 <p><b>G7W</b> YOKO DELTA HOWLITE</p>	 <p><b>G7K</b> SOHO CRISTAL</p>
 <p><b>G7L</b> SOHO MÉTAL</p>	 <p><b>G4P</b> COLLECTION "O"</p>	 <p><b>G5D</b> ANOVA</p>	 <p><b>G5A</b> NANO</p>	 <p><b>G5B</b> NANO à manettes with lever handles</p>
 <p><b>U2A</b> LE 11</p>	 <p><b>U2B</b> LE 11 à manettes with lever handles</p>	 <p><b>A6A</b> PROFIL</p>	 <p><b>A6B</b> PROFIL à manettes with lever handles</p>	 <p><b>A6N</b> PROFIL ONYX</p>



**A6P** P. 39  
**PROFIL ONYX**  
 à manettes  
 with lever handles



**G1T** P. 41  
**BELUGA**



**G1U** P. 41  
**BELUGA** à manettes  
 with lever handles



**G04** P. 43  
**PURE**



**U3J** P. 47  
**ESTRELA**



**U3K** P. 47  
**ESTRELA** à manettes  
 with lever handles



**U3L** P. 47  
**ESTRELA** inserts couleur  
 with color inlays



**G4R** P. 49  
**HAMPTONS**



**G4S** P. 49  
**HAMPTONS** à manettes  
 with lever handles



**G8A** P. 51  
**LES ONDES**



**G8B** P. 51  
**LES ONDES** à manettes  
 with lever handles



**U9K** P. 53  
**GRAND CENTRAL**



**U9L** P. 53  
**GRAND CENTRAL**  
 à manettes  
 with lever handles



**U9M** P. 53  
**GRAND CENTRAL**  
 onyx noir  
 black onyx



**U9N** P. 53  
**GRAND CENTRAL**  
 onyx noir à manettes  
 black onyx with lever  
 handles



**U9R** P. 53  
**GRAND CENTRAL**  
 onyx blanc  
 white onyx



**U9S** P. 53  
**GRAND CENTRAL**  
 onyx blanc à manettes  
 white onyx with lever  
 handles



**U9A** P. 55  
**WEST COAST**



**U9B** P. 55  
**WEST COAST** à manettes  
 with lever handles



**U9C** P. 55  
**WEST COAST**  
 guilloché lin  
 guilloché



**U9D** P. 55  
**WEST COAST**  
 guilloché lin à manettes  
 guilloché with lever  
 handles



**U9E** P. 55  
**WEST COAST**  
 onyx noir  
 black onyx



**U9F** P. 55  
**WEST COAST**  
 onyx noir à manettes  
 black onyx with lever  
 handles



**U9G** P. 55  
**WEST COAST**  
 onyx blanc  
 white onyx



**U9F** P. 55  
WEST COAST  
onyx blanc à manettes  
white onyx with lever  
handles



**G7H** P. 57  
CLUB SAINT-GERMAIN



**G7J** P. 57  
CLUB SAINT-GERMAIN  
à manettes  
with lever handles



**G7C** P. 59  
SAINT-GERMAIN



**G7D** P. 59  
SAINT-GERMAIN  
à manettes  
with lever handles



**G7A** P. 61  
BEAUBOURG



**G7B** P. 61  
BEAUBOURG à manettes  
with lever handles



**G2K** P. 63  
FAUBOURG  
PORCELAINE BLANCHE



**G2J** P. 63  
FAUBOURG  
PORCELAINE BLANCHE  
à manettes  
with lever handles



**G2L** P. 63  
FAUBOURG  
PORCELAINE NOIRE



**G2M** P. 63  
FAUBOURG  
PORCELAINE NOIRE  
à manettes  
with lever handles



**G2T** P. 65  
FAUBOURG MÉTAL



**G2U** P. 65  
FAUBOURG MÉTAL  
à manettes  
with lever handles



**G2H** P. 67  
LE 9 HOWLITE



**G2I** P. 67  
LE 9 NERO MARQUINA



**G69** P. 69  
SPIRIT



**G58** P. 69  
SPIRIT à manettes  
with lever handles



**G7E** P. 71  
DEAN



**G7F** P. 73  
BONDI



**G7G** P. 73  
BONDI à manettes  
with lever handles



**G9A** P. 77  
SYSTEM



**G9B** P. 77  
SYSTEM à manettes  
with lever handles



**G9C** P. 77  
SYSTEM diamant  
diamond



**G9D** P. 77  
SYSTEM diamant  
à manettes  
diamond with lever  
handles



**G9E** P. 77  
SYSTEM quadrillé  
square





**G9F** P. 77  
SYSTEM quadrillé à manettes  
squared with lever handles



**G9G** P. 77  
SYSTEM howlite



**G9H** P. 77  
SYSTEM howlite à manettes  
with lever handles



**G9J** P. 77  
SYSTEM cristal  
crystal



**G9K** P. 77  
SYSTEM cristal à manettes  
crystal with lever handles



**G3R** P. 79  
MONTAIGNE  
Grand Antique



**G3S** P. 79  
MONTAIGNE  
Grand Antique à manettes  
with lever handles



**G3T** P. 79  
MONTAIGNE  
Leonardo Grey



**G3U** P. 79  
MONTAIGNE  
Leonardo Grey à manettes  
with lever handles



**G3V** P. 79  
MONTAIGNE  
Venus White



**G3W** P. 79  
MONTAIGNE  
Venus White à manettes  
with lever handles



**G6A** P. 81  
MÉTAMORPHOSE



**G6B** P. 81  
MÉTAMORPHOSE à manettes  
with lever handles



**G6C** P. 81  
MÉTAMORPHOSE à manettes carbone  
with carbon lever handles



**G6D** P. 81  
MÉTAMORPHOSE à manettes céramique  
noire  
with black ceramic lever handles



**G6E** P. 81  
MÉTAMORPHOSE à manettes céramique  
blanche  
with white ceramic lever handles



**U8D** P. 83  
CORVAIR



**U8E** P. 83  
CORVAIR à manettes  
with lever handles



**U8F** P. 83  
CORVAIR Howlite



**U8G** P. 83  
CORVAIR Howlite à manettes  
with lever handles



**U8H** P. 83  
CORVAIR Portoro



**U8J** P. 83  
CORVAIR Portoro à manettes  
with lever handles



**U8K** P. 83  
CORVAIR Fior di Bosco



**U8L** P. 83  
CORVAIR Fior di Bosco à manettes  
with lever handles



**A9B** P. 87  
JAIPUR cristal  
crystal



**A9B** P. 87  
JAIPUR onyx noir  
black onyx



**A9C** P. 87  
JAIPUR métal  
metal



**U1A** P. 89  
MANDARINE



**U1D** P. 89  
MANDARINE cristal clair  
clear crystal



**U1E** P. 89  
MANDARINE  
cristal satiné  
satin crystal



**U1K** P. 89  
MANDARINE  
cristallia diamant



**E53** P. 91  
NAJEM



**U4A** P. 93  
DIPLOMATE  
bagues lisses  
plain rings



**U4B** P. 93  
DIPLOMATE  
bagues annelées  
ringed rings



**U4C** P. 93  
DIPLOMATE  
bagues torsadées  
twisted rings



**U4D** P. 93  
DIPLOMATE royale



**A54** P. 95  
ART DÉCO



**A55** P. 95  
ART DÉCO à manettes  
with lever handles



**A56** P. 95  
ART DÉCO cristal  
crystal



**A57** P. 95  
TRADITION



**A58** P. 95  
TRADITION à manettes  
with lever handles



**A59** P. 95  
TRADITION cristal  
crystal



**G29** P. 97  
CHARLESTON



**G75** P. 97  
CHARLESTON  
à manettes  
with lever handles



**G3N** P. 97  
CHARLESTON  
à manettes métal  
with metal lever handles



**G25** P. 99  
1900



**G28** P. 99  
1900 à manettes  
with lever handles



**G3M** P. 99  
1900 à manettes métal  
with metal lever handles



**A52** P. 101  
BROADWAY



**A04** P. 101  
BROADWAY à manettes  
with lever handles



**U4E** P. 103  
DUOMO



**U4F** P. 103  
DUOMO CRISTAL



**U93** P. 105  
MALMAISON



**U95** P. 105  
MALMAISON PORTORO



**G24** P. 107  
AMOUR DE TRIANON



**G31** P. 107  
CYGNE



**G99** P. 107  
TÊTE DE LION



**G14** P. 107  
VERSAILLES



**U6F** P. 113  
BEYOND CRYSTAL  
clair  
clear



**U6G** P. 113  
BEYOND CRYSTAL  
aqua



**U6H** P. 113  
BEYOND CRYSTAL  
rouge  
red



**U6J** P. 113  
BEYOND CRYSTAL  
champagne



**U6K** P. 113  
BEYOND CRYSTAL  
bleu  
blue



**U6A** P. 115  
PÉTALE DE CRISTAL  
clair  
clear



**U6B** P. 115  
PÉTALE DE CRISTAL  
bleu  
blue



**U6C** P. 115  
PÉTALE DE CRISTAL  
rouge  
red



**U6D** P. 115  
PÉTALE DE CRISTAL  
noir  
black



**U6E** P. 115  
PÉTALE DE CRISTAL  
liseré doré  
gold edging



**A4J** P. 119  
HIRONDELLES clair  
clear



**A4K** P. 119  
HIRONDELLES platine  
platinum



**A4L** P. 119  
HIRONDELLES doré  
gold



**A2A** P. 121  
MÉTROPOLIS clair  
clear



**A2B** P. 121  
MÉTROPOLIS à manettes  
clair  
clear with lever handles



**A2L** P. 121  
MÉTROPOLIS noir  
black



**A2M** P. 121  
MÉTROPOLIS à manettes  
noir  
black with lever handles



**A2R** P. 123  
MASQUE DE FEMME  
LUNAIRE



**A2S** P. 123  
MASQUE DE FEMME  
SOLAIRE



**A2T** P. 123  
MASQUE DE FEMME  
GRAVÉ



**A2U** P. 123  
MASQUE DE FEMME  
LISSE



**A2G** P. 125  
ANGE



**A2F** P. 125  
NAÏADE



**A2H** P. 127  
PANTHÈRE clair  
clear



**A2K** P. 127  
PANTHÈRE noir  
black



**A33** P. 129  
BAMBOU noir  
black



**A34** P. 129  
BAMBOU ambre  
amber



**A35** P. 129  
BAMBOU clair  
clear



**A2C** P. 131  
OCÉANIA



**A2J** P. 131  
PAPILLON



**A2E** P. 131  
VENISE



**A41** P. 133  
DAHLIA



**A6G** P. 135  
PROFIL CRISTAL



**A6H** P. 135  
PROFIL CRISTAL  
à manettes  
with lever handles



**A2N** P. 137  
MOSSI



**U5K** P. 141  
CAMÉLIA CRISTAL NOIR



**U5L** P. 141  
CAMÉLIA CRISTAL  
CLAIR



**U5D** P. 143  
DRAGON SUN



**U5J** P. 145  
ROSE



**U5N** P. 147  
NEW ISLAND



**U5P** P. 149  
NEW PARADISE



**U5E** P. 151  
GINKGO



**U5F** P. 153  
VEGETAL



**U5A** P. 155  
FLORE



**U2D** P. 159  
INFINI



**U2E** P. 159  
INFINI platine  
platinum



**U2F** P. 159  
INFINI doré  
gold



**U2L** P. 161  
NIHAL bleu  
blue



**U2M** P. 161  
NIHAL métal  
metal



**U2N** P. 161  
NIHAL doré  
gold



**U2P** P. 161  
NIHAL noir  
black



**U2R** P. 161  
NIHAL vert  
green



**U2S** P. 161  
NIHAL rouge  
red



**A7A** P. 163  
ITHAQUE doré  
gold



**A7B** P. 163  
ITHAQUE platine  
platinum



**A7F** P. 165  
MARQUISE doré  
gold



**A7G** P. 165  
MARQUISE platine  
platinum



**U8B** P. 167  
MONTE CARLO doré  
gold



**U8C** P. 167  
MONTE CARLO platine  
platinum



**G2N** P. 169  
FROUFROU



**G2P** P. 169  
FROUFROU à manettes  
with lever handles



**G2R** P. 169  
FRIVOLE



**G2S** P. 169  
FRIVOLE à manettes  
with lever handles



**A8M** P. 173  
VOGUE malachite



**A8N** P. 173  
VOGUE jaspe rouge  
red jasper



**A8P** P. 173  
VOGUE onyx noir  
black onyx



**A8R** P. 173  
VOGUE œil de tigre  
tiger's eye



**A8S** P. 173  
VOGUE lapis lazuli



**A1J** P. 175  
AMBOISE malachite



**A1K** P. 175  
AMBOISE lapis lazuli



**A1L** P. 175  
AMBOISE jaspe rouge  
red jasper



**A1M** P. 175  
AMBOISE onyx noir  
black onyx



**A1S** P. 177  
CHEVERNY malachite



**A1T** P. 177  
CHEVERNY lapis lazuli



**A1U** P. 177  
CHEVERNY jaspe rouge  
red jasper



**U1V** P. 177  
CHEVERNY onyx noir  
black onyx



**A1V** P. 177  
SULLY malachite



**A1W** P.177  
SULLY lapis lazuli



**A1X** P. 177  
SULLY jaspe rouge  
red jasper



**U1S** P. 177  
SULLY onyx blanc  
white onyx



**U1T** P. 177  
SULLY onyx noir  
black onyx



**U7A** P. 179  
TROCADERO malachite



**U7B** P. 179  
TROCADERO lapis lazuli



**U7C** P. 179  
TROCADERO jaspe rouge  
red jasper



**U7D** P. 179  
TROCADERO onyx noir  
black onyx



**U7E** P. 179  
TROCADERO œil de tigre  
tiger's eye

QUELQUES RÉFÉRENCES SOME REFERENCES



**PENINSULA**  
Shanghai  
Collection Ange  
by Lalique

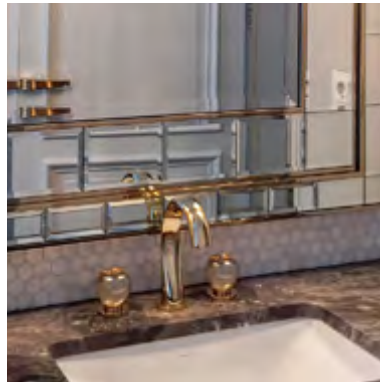

**KAPLAN RESIDENCE**  
Berlin  
Collection Pomme  
by Lalique

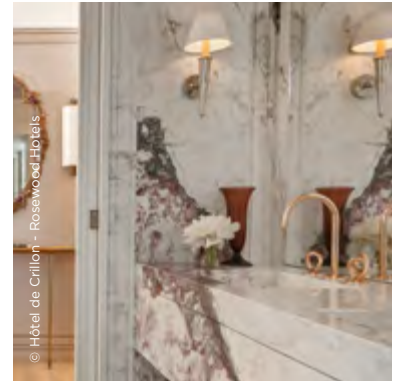

**HÔTEL DE CRILLON**  
Paris  
Collection «O»  
by Christofle & Studio Putman



**VILLA BEL AIR**  
Los Angeles  
Collection Le 11  
by Alberto Pinto

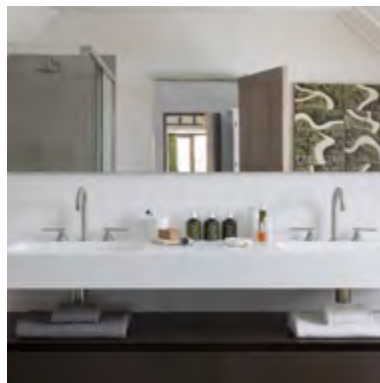

**FARM HOUSE**  
Belgium  
Collection Dean

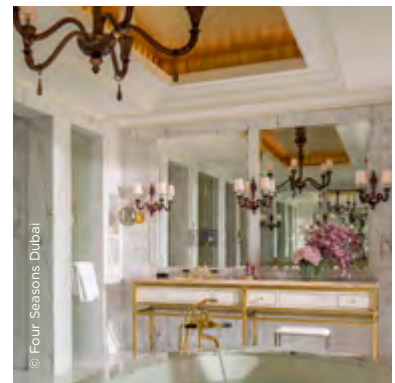

**FOUR SEASONS**  
Dubai  
Collection Bambou  
by Lalique

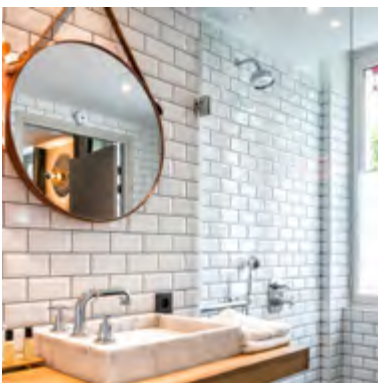

**LE BŒUF COURONNÉ**  
Paris  
Collection Saint-Germain



**THE KEYS AT QUINTA**  
Quinta do Lago  
Collection Spirit à manettes

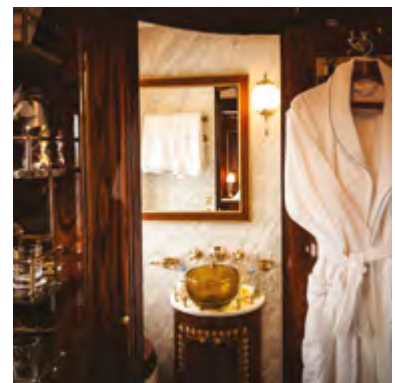

**ORIENT EXPRESS**  
Venice Simplon Company  
Collection Charleston

**The Dorchester** London  
**Emirates Palace Hotel** Abu Dhabi  
**Sofitel Cataract** Aswan  
**Sofitel Airport** Athens  
**Four Seasons** Bahrein  
**Burj Al Arab** Dubai  
**Jumeirah Beach** Dubai  
**Four Seasons** Firenze  
**Shangri-La Bosphorus Plaza** Istanbul  
**Pangu** Brussels  
Beijing

**Fairmont Hotel** Guiyang  
**Green Town Sapphire Mansion** Hangzhou  
**China Eastern** Shanghai  
**Martinez** Cannes  
**Cheval Blanc** Courchevel  
**Normandy & Royal** Deauville  
**Marriott** Issy-les-Moulineaux  
**Hermitage** Monaco  
**Monte Carlo Bay** Monaco  
**Bristol** Paris  
**Cheval Blanc** Paris

**Fouquet's** Paris  
**Four Seasons Georges V** Paris  
**Plaza Athénée** Paris  
**Shangri-La** Paris  
**Hotel de Paris** St Tropez  
**Grand Hôtel du Lac** Vevey  
**Bellagio** Las Vegas  
**Caesars Palace** Las Vegas  
**One Hanson Place** New York  
**Zoo Hotel** Berlin  
**Park Hyatt** Vienna





# CONTEMPORAIN

Découvrez les collections contemporaines THG Paris aux lignes graphiques et épurées. Elles s'associent parfaitement aux finitions chrome ou graphite.

Discover by THG Paris' contemporary collections made of graphics and refined lines. Polished chrome or graphite finishes suit them perfectly.



CONTEMPORAIN

# ICON-X

Design by  
**STUDIO F·A·PORSCHE**

**“GOOD DESIGN  
MUST BE HONEST.”**

*Prof. Ferdinand Alexander Porsche*

Un design affirmé et intemporel, au-delà des tendances.

An assertive and timeless design that goes beyond trends.



reddot winner 2021



MÉTAL  
METAL

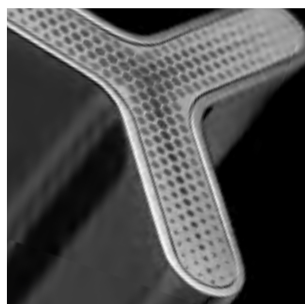

INSERTS TITANE  
TITANIUM INLAYS

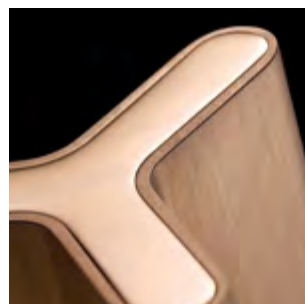

INSERTS MÉTAL  
METAL INLAYS

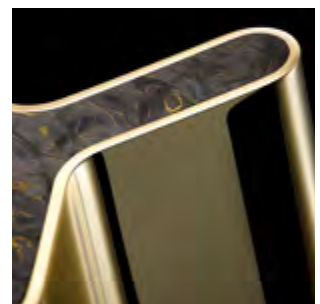

INSERTS CARBONE GOLD  
CARBONE GOLD INLAYS



CONTEMPORAIN

# YOKO





CONTEMPORAIN

# SOHO

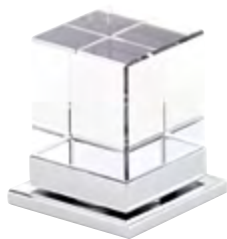



*Christofle*  
PARIS



## COLLECTION O



### STUDIO PUTMAN

Le Studio Putman propose une approche singulière des objets et des espaces. L'anneau imaginé par Andrée Putman pour Christofle en 2002 que l'on retrouve dans la collection « O » incarne à la perfection l'idée du luxe contemporain.

« Notre métier consiste à choisir des formes, à inventer des équilibres, à trouver des cohérences. Ce n'est finalement, pas tellement différent de la vie. »

Olivia Putman

Studio Putman offers a singular approach to objects and spaces. The ring created by Andrée Putman for Christofle in 2002, which can be found in the "O" collection, embodies perfectly the concept of contemporary luxury.

"Our work consists of choosing forms, inventing balances, finding consistencies. In the end, it's not so different from life."

Olivia Putman



CONTEMPORAIN

# ANOA





CONTEMPORAIN

# NANO





**LE 11**



**PINTO**

C'est en travaillant sur des projets de yachts ou de villas prestigieuses que THG Paris et Alberto Pinto se sont rencontrés. Comme une suite logique, ce dernier a proposé de créer une série de robinetterie exclusive, aux lignes fluides et au design épuré.

THG Paris and Alberto Pinto met while working on projects for yachts and prestigious villas. As an obvious consequence, Alberto Pinto proposed the creation of an exclusive series of taps with fluid lines and a pure design.







# PROFIL



## JAMIE DRAKE

Jamie Drake, célèbre designer d'intérieur new-yorkais, est connu pour son approche intrépide de la couleur et sa sensibilité pour la mode.

Famed designer Jamie Drake, a New York based style icon, is known for his fearless approach to color as well as his fashion-conscious sensibility.



CONTEMPORAIN

# BELUGA





CONTEMPORAIN

# PURE





# TRANSITIONNEL

Le style transitionnel associe le confort et la chaleur du style traditionnel avec les lignes épurées et les formes sobres du design contemporain. Le résultat de cette harmonie parfaite : des robinetteries élégantes aux détails soignés.

Les finitions nickel, bronze ou or pâle y sont très souvent associées.

The transitional style combines the comfort and the warmth of the traditional style with the pure lines and understated shapes of the contemporary design. The result of this perfect harmony: elegant fittings with careful details.

Polished nickel, lacquered bronze or soft gold finishes are often associated with this style.





**ESTRELA****CHAMPALIMAUD**

Alexandra Champalimaud est la directrice et fondatrice de l'entreprise d'architecture d'intérieur du même nom, basée à New-York. Spécialiste de l'hôtellerie sur mesure et du design résidentiel, guidée par une vision très raffinée des espaces, Alexandra crée des environnements contemporains luxueux et audacieux. Ses thèmes de prédilection : la nature, l'histoire et les arts décoratifs.

Alexandra Champalimaud is the principal and founder of her eponymous New York City-based, full-service interiors and planning firm, Champalimaud. Specializing in bespoke hospitality and residential design and guided by her sophisticated vision, Alexandra creates bold, luxury environments that are both contemporary and rooted in the context of nature, history, and the decorative arts.





# CharlesZana

Depuis Paris, Londres, New York et Monaco, Charles Zana confirme depuis trente ans son expertise d'architecte. Il métamorphose avec goût intérieurs résidentiels et lieux publics. Formé à l'école des Beaux-Arts de Paris, il forge son écriture, son style et ses lignes de force au contact des lieux que lui confient ses clients.

For the last thirty years, from Paris to London via New York and Monaco, Charles Zana has provided finesse and expertise to the world's most beautiful interiors. In three decades, Zana, who studied architecture at the Paris's School of Fine Arts, has defined his unique style sought by his clients who seek the exclusive vision of this art lover, creatively passionate about design.

TRANSITIONNEL

# HAMPTONS





# LES ONDES

Complémentaires en toute chose, Patrick Gilles et Dorothée Boissier maîtrisent avant tout l'art du désaccord. Ils entretiennent une opposition constructive qui équilibre chaque projet. C'est donc nourris par cette contradiction essentielle qu'ils signent en duo des projets créatifs dont l'élégance et la maturité sont plébiscitées par tous.

Complimentary in every way, Patrick Gilles and Dorothée Boissier master above all the art of discord. They maintain a constructive opposition which balances each project. Hence it is through this essential contradiction that this talented duo sign creative projects, which are internationally recognized for their elegance and maturity.







TRANSITIONNEL

# GRAND CENTRAL

Avec des bureaux à Paris et à Los Angeles, la philosophie de Timothy Corrigan associe élégance européenne et confort californien. Il est le premier designer américain récompensé par le patrimoine français pour la restauration de plusieurs monuments nationaux en France.

With offices in Paris and Los Angeles, Timothy Corrigan's timeless design philosophy combines European elegance with California comfort. He was the first American designer honored by French Heritage for his restoration of several national landmarks in France.







# WEST COAST



Pour la collection West Coast, Timothy Corrigan associe le classicisme français et l'audace américaine.

For the West Coast collection, Timothy Corrigan combines French classicism with American audacity.





# CLUB SAINT-GERMAIN





TRANSITIONNEL

# SAINT-GERMAIN





TRANSITIONNEL

# BEAUBOURG







# FAUBOURG PORCELAINE



*PYR*

PIERRE-YVES ROCHON

Sa première collaboration avec THG Paris remonte à 2005. De ce partenariat est née une relation de confiance qui a permis de développer des lignes de robinetteries et d'accessoires au style très raffiné. Avec Faubourg, Pierre-Yves Rochon signe une collection synonyme de « chic à la française ».

The collaboration with THG Paris started in 2005. A mutual confidence and respect has emerged from this partnership, allowing the creation of taps and fittings collections in a refined style. With Faubourg, Pierre-Yves Rochon creates a collection synonymous with "French chic".





# FAUBOURG MÉTAL



*PY*

PIERRE-YVES ROCHON

Pierre-Yves Rochon a vécu toute sa jeunesse dans de nombreux pays étrangers, ce qui a aiguisé sa curiosité du monde et l'a ouvert à tous les courants culturels et artistiques. Avant d'ouvrir son propre cabinet à 30 ans, il a travaillé pour de grandes enseignes et chez des décorateurs contemporains, expérimentant ainsi toutes les tendances et tous les styles, du plus classique au plus futuriste.

Pierre-Yves Rochon spent his childhood in numerous foreign countries, which sharpened his interest for the world and gave him an open-mindedness regarding all the cultural and artistic trends. Before opening his office proper at 30 years old, he worked for well-known brand-names, for contemporary decorators where he could test all the trends and styles from the most classical to the most futurist.





BURBERRY  
WEEKEND  
FOR WOMEN  
EAU DE PARFUM  
NAPHEE BLEUET CAPSULEAU  
100ml e 3.3 FL.OZ.

**LE 9**

*PYR*

PIERRE-YVES ROCHON

Pierre-Yves Rochon associe une nouvelle fois sa créativité au savoir-faire de THG Paris, en créant la collection « Le 9 ». En référence à l'adresse du cabinet Pierre-Yves Rochon, le 9 avenue Matignon, cette collection vient s'inscrire dans la lignée des créations emblématiques de THG Paris.

Pierre-Yves Rochon once again combines his creativity with the know-how of the THG Paris, creating "Le 9" collection. Referring to the address of Pierre-Yves Rochon, 9 avenue Matignon, this collection comes in line with the House's iconic creations.





TRANSITIONNEL

# SPIRIT







TRANSITIONNEL

# DEAN





TRANSITIONNEL

# BONDI

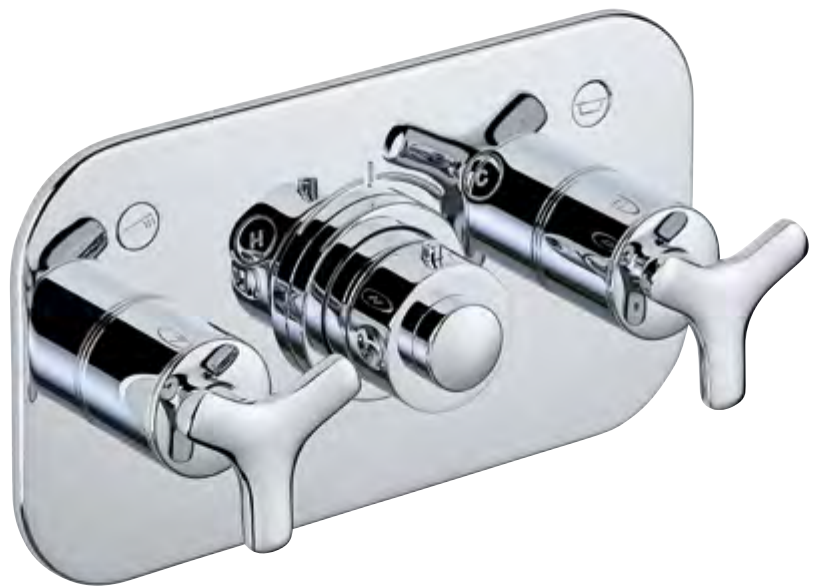



# CLASSIC DESIGN

Nos collections Classic Design ont été pensées pour ceux qui aiment l'originalité, les formes uniques et sortir des standards. Des collections au design affirmé qui ne laisseront personne indifférent.

Our Classic Design collections have been designed for those who love originality, unique shapes and going beyond the standards. Collections with an assertive design that will leave no one indifferent.



**SYSTEM**
**ARIK LEVY**  
 ART&DESIGN STUDIO

Artiste, technicien, photographe, designer, vidéaste, les compétences d'Arik Levy sont multidisciplinaires et son travail peut être vu dans des galeries prestigieuses et des musées du monde entier. Si le robinet est le bijou de la salle de bain, Arik Levy l'a voulu, non pas à son image uniquement, mais personnalisable par chacun.

Artist, technician, photographer, designer, video artist, Levy's skills are multi-disciplinary and his work can be seen in prestigious galleries and museums worldwide. If the tap is the gem of the bathroom, Arik Levy does not want each gem to solely reflect his image, but rather to be customizable by its owner.









# MONTAIGNE

De son enfance à Hong-Kong, l'architecte d'intérieur et décoratrice Stéphanie Coutas a conservé une appétence intuitive pour le métissage des cultures et le raffinement d'un art de vivre haut de gamme, dénué de toute ostentation. Un style néoclassique et contemporain qui revisite avec une audace assumée toutes les époques et les courants des arts décoratifs.

Ever since her childhood in Hong Kong, the interior designer and decorator Stephanie Coutas has retained an intuitive appetite for the mixing of cultures and the refinement "art de vivre" with no show of ostentation. A neoclassical and contemporary style which revisits all the eras and trends of decorative art with audacity.





# MÉTAMORPHOSE



## STUDIO PUTMAN

« Ma première rencontre avec les équipes de THG Paris fut un véritable choc. L'excellence et la beauté de leurs savoir-faire, l'enthousiasme et la fierté des artisans m'ont profondément émue. »

"My first meeting with THG Paris's teams was a total shock. The excellence and beauty of their expertise, the enthusiasm and pride of the craftsmen deeply moved me."

Olivia Putman



# CORVAIR

« Cette collection est un rêve éveillé de formes somptueuses et de détails émouvants, synonymes de l'élégance du Voyage. » Martin Kemp.

"This collection is a lucid dream of the sumptuous forms and emotive detailing synonymous with the elegance of Voyage." Martin Kemp





# INTEMPOREL

Les classiques de THG Paris.

Depuis un demi-siècle, des designers se sont inspirés de notre ADN en y ajoutant, tout en nuances, leur personnalité. Ainsi sont nés les intemporels. Malmaison, Mandarine, Jaipur, Charleston... Évocateurs, chacun de ces noms commence une histoire qui n'a pas de fin.

THG Paris classics. For half a century, a few designers have been inspired by the DNA of THG Paris while adding a little touch of their personality. The timeless "Intemporel" collection was born. Malmaison, Mandarine, Jaipur, Charleston, .. these names tell stories that have a beginning and no end.





INTEMPOREL

# JAIPUR





INTEMPOREL

# MANDARINE





INTEMPOREL

# NAJEM





INTEMPOREL

# DIPLOMATE







# ART DÉCO - TRADITION





INTEMPOREL

# CHARLESTON





**1900**





# BROADWAY

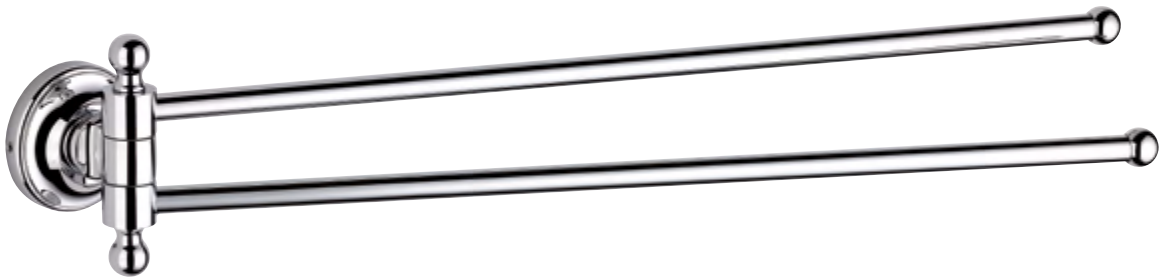
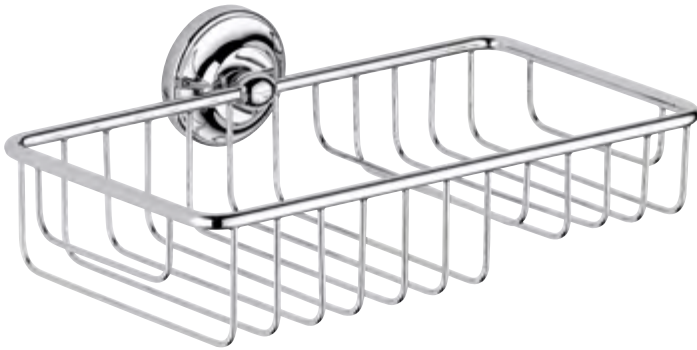





INTEMPOREL

# DUOMO





## MALMAISON



*Christofle*  
PARIS

Depuis 1830, Christofle dompte et sublime l'argent, matière à part : éclatante sans tapage, intelligente sans prétention, versatile mais sincère. Parmi les premières créations de THG Paris en partenariat avec la Maison Christofle, la collection Malmaison emprunte et réinvente les codes du baroque.

Since 1830, Christofle has been taming and beautifully enhancing silver, a material unlike any other: shiny without being showy, unpretentiously intelligent and versatile yet sincere. Among the first creations of THG Paris, in partnership with the Christofle company, the Malmaison collection uses and reinvents Baroque codes.





**MEN**

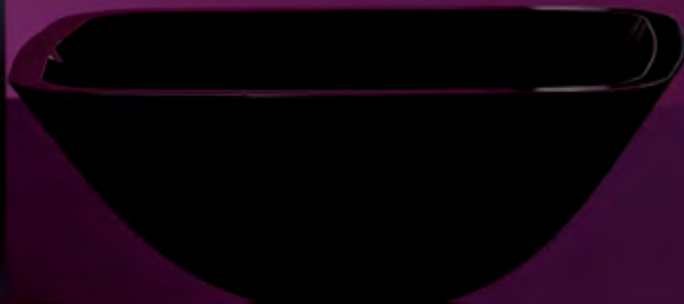

# LES BAROQUES





# PRESTIGE

Les collections Prestige de THG Paris font partie de l'ADN de la maison. Habillées de cristal ou de porcelaine, les robinetteries Prestige ont souvent une forme classique mais affichent une élégance rare. Les finitions dorées et or pâle s'accordent à merveille avec les designs prestigieux.

The Prestige collections from THG Paris are part of the company's DNA. Adorned by crystal or porcelain, Prestige bathroom fittings often have a classic shape but reveal a rare elegance. The gold or pale gold finishes match perfectly with the eminent designs.







FONDÉE EN 1764 À BACCARAT, SUR  
AUTORISATION DU ROI LOUIS XV, LA  
MANUFACTURE NE CESSE DÈS LORS  
SON ASCENSION, REPOUSSANT LES  
FRONTIÈRES DE LA CRÉATION, ET  
FAISANT RAYONNER LE PRESTIGE DU  
CRISTAL AUX QUATRE COINS DU GLOBE.

EPAULÉE PAR LE TALENT DE 24  
MEILLEURS OUVRIERS DE FRANCE ET  
D'UN MAÎTRE D'ART, LA CRISTALLERIE  
S'INSPIRE DEPUIS TOUJOURS DE  
SES RACINES, DE SA VOCATION  
ARTISANALE ET DE SON PATRIMOINE  
POUR MIEUX TRANSFIGURER LES  
TRADITIONS EN CRÉATIONS.

FOUNDED IN 1764 BY APPOINTMENT OF  
KING LOUIS XV, BACCARAT HAS BEEN  
CONTINUALLY GROWING, PUSHING  
THE BOUNDARIES OF CREATION  
AND SPREADING THE PRESTIGE OF  
CRYSTAL THROUGHOUT THE WORLD.

SUPPORTED BY THE TALENTS OF 24 “BEST  
FRENCH CRAFTSMEN” AND A MASTER  
CRAFTSMAN, THE CRYSTAL WORKS HAS  
ALWAYS DRAWN INSPIRATION FROM  
ITS ROOTS, ITS CRAFTSMANSHIP AND  
ITS HERITAGE TO BETTER TRANSFORM  
THE TRADITIONS INTO CREATIONS.

**BACCARAT**

*Baccarat*



*Baccarat*

## BEYOND CRYSTAL



REMI  
TESSIER

DESIGN

Architecte de l'intemporel, Rémi Tessier aime la perfection teintée d'audace, l'émotion ultime du beau et cette texture impalpable que l'on nomme « l'âme » d'un lieu.

« Diffuser la lumière dans des blocs de cristal, marier fonctionnalité et esthétisme, m'est apparu comme une évidence pour passer de l'obscurité à la lumière. »

Timeless architect, Rémi Tessier loves the audacity of perfection, the final sensation of beauty and the ethereal feel that we call "the soul" of a place.

"Diffusing light in crystal blocks, combining functionality and aesthetics, seemed to me an obvious way to move from darkness to light."





*Baccarat*



PIERRE-YVES ROCHON

PRESTIGE

## PÉTALE DE CRISTAL

Pétale de Cristal est l'association originale de deux savoir-faire de prestige. De cette rencontre est née une collection unique d'inspiration florale, imaginée par le designer Pierre-Yves Rochon.

Pétale de Cristal is the original association of two prestigious skills. From this encounter was born a unique collection of floral inspiration, imagined by the designer Pierre-Yves Rochon.







© Reto Guntj • Villa Rene Lalique • Collection Venice

DEPUIS 1921, LA MANUFACTURE LALIQUE  
INSTALLÉE EN ALSACE, RÉGION DE  
TRADITION VERRIÈRE, PERPÉTUE UN  
VÉRITABLE SAVOIR-FAIRE ARTISANAL.

LE STYLE LALIQUE NAÎT SOUS LE GESTE  
DE L'ARTISTE ESQUISSANT UN DESSIN  
EN OSMOSE TOTALE AVEC LA MATIÈRE,  
UN STYLE RECONNAISSABLE AU  
MODELAGE MANUEL DES PIÈCES ET DES  
DÉCORS, COMME UNE SCULPTURE, À LA  
CARACTÉRISTIQUE DE CRISTAL CLAIR ET  
SATINÉ. UNE CULTURE DE LA DOUCEUR,  
DE LA FÉMINITÉ, DE LA NATURE  
NOURRIE D'UNE FORTE INSPIRATION  
ART NOUVEAU ET ART DÉCO.

FOR MORE THAN 100 YEARS,  
LALIQUE'S MANUFACTURE LOCATED  
IN ALSACE, AREA RENOWNED FOR  
ITS GLASSMAKING, HAS PERPETUATED  
A TRADITIONAL KNOW-HOW.

THE LALIQUE STYLE COMES FROM  
AN ARTISTIC GESTURE, OUTLINING  
A DRAWING IN TOTAL OSMOSIS  
WITH CRYSTAL, A STYLE THAT ONE  
EASILY RECOGNIZES THROUGH THE  
MANUAL MODELING OF THE SHAPES  
AND PATTERNS, AS IF SCULPTURED,  
THE RICHNESS OF THE FIGURATIVE  
DETAILS, THE DIFFERENT TYPES OF  
FINISHING WHICH CREATES THIS  
CHARACTERISTIC CONTRAST OF CLEAR  
AND MATT CRYSTAL. AN IDENTITY  
BUILT BY SOFTNESS, FEMININITY,  
NATURE WITH STRONG ART NOUVEAU  
AND ART DECO INSPIRATIONS.

# LALIQUE

LALIQUE



LALIQUE



PRESTIGE

# HIRONDELLES





LALIQUE

PRESTIGE

# MÉTROPOLIS

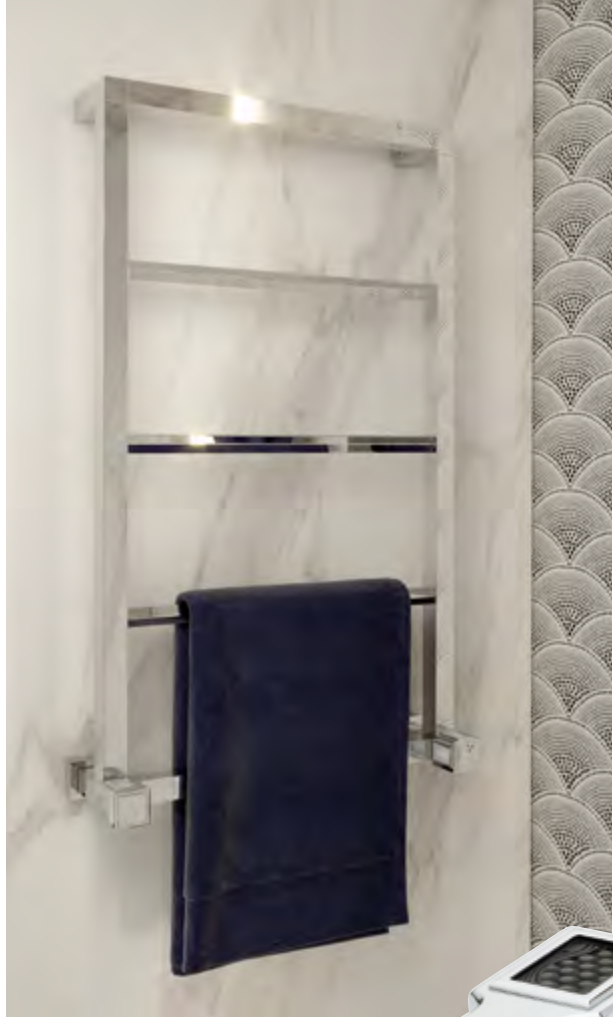



LALIQUE

PRESTIGE

# MASQUE DE FEMME





LALIQUE

PRESTIGE

# ANGE - NAÏADE





LALIQUE



PRESTIGE

# PANTHÈRE





LALIQUE

PRESTIGE

# BAMBOU





LALIQUE

# OCÉANIA - PAPILLON - VENICE





LALIQUE

PRESTIGE

# DAHLIA





LALIQUE



# PROFIL CRISTAL





LALIQUE

PRESTIGE

**MOSSI**







© Martin Kemp Design • Private penthouse in London • Collection Vegetal

DAUM, MAÎTRE-VERRIER LÉGENDAIRE, ENTRETIENT DEPUIS PLUS D'UN SIÈCLE UNE RELATION D'AMOUR AVEC LES PLUS GRANDS ARTISTES DE SON TEMPS.

SI LA TECHNIQUE DE LA PÂTE DE VERRE EXISTE DEPUIS L'ANTIQUITÉ, DAUM LA REDÉCOUVRE EN 1968 EN LA RETRAVAILLANT AVEC DU CRISTAL. PAR UN PROCÉDÉ DE FONDERIE ET DE MOULAGE À LA CIRE PERDUE, CETTE TECHNIQUE ARTISANALE ASSURE UN RENDU DE MATIÈRE TRÈS PARTICULIER, IMPOSSIBLE À OBTENIR AVEC UNE TECHNIQUE TRADITIONNELLE DE CRISTAL SOUFLÉ.

DAUM, THE LEGENDARY GLASSMAKER MASTER, HAS KEPT ALIVE FOR MORE THAN A CENTURY A LOVE RELATIONSHIP WITH THE GREATEST ARTISTS OF ITS TIME.

ALTHOUGH THE "PÂTE DE VERRE" TECHNIQUE HAS EXISTED SINCE ANTIQUITY, DAUM REDISCOVERED IT IN 1968 WHEN IT INVENTED A METHOD OF REWORKING IT USING CRYSTAL. CASTING A PIECE USING THIS LOST-WAX PROCESS ENSURES THE PERFECT REGULARITY OF ITS CONTOURS, WHICH WOULD BE IMPOSSIBLE TO OBTAIN USING TRADITIONAL CRYSTAL OR GLASSBLOWING METHODS, AS WELL AS AN INSTANTLY RECOGNIZABLE, GRAINY APPEARANCE.

DAUM

Daum  
FRANCE 1878



*Daum*  
FRANCE 1878

PRESTIGE

# CAMÉLIA





*Daum*  
FRANCE 1878



# SUN DRAGON





**Daum**  
FRANCE 1878

PRESTIGE

# ROSE





*Daum*  
FRANCE 1878

PRESTIGE

# NEW ISLAND





**Daum**  
FRANCE 1878

# NEW PARADISE





*Daum*  
FRANCE 1878



PRESTIGE

# GINKGO





*Daum*  
FRANCE 1878

PRESTIGE

# VEGETAL





*Daum*  
FRANCE 1878

PRESTIGE

# FLORE





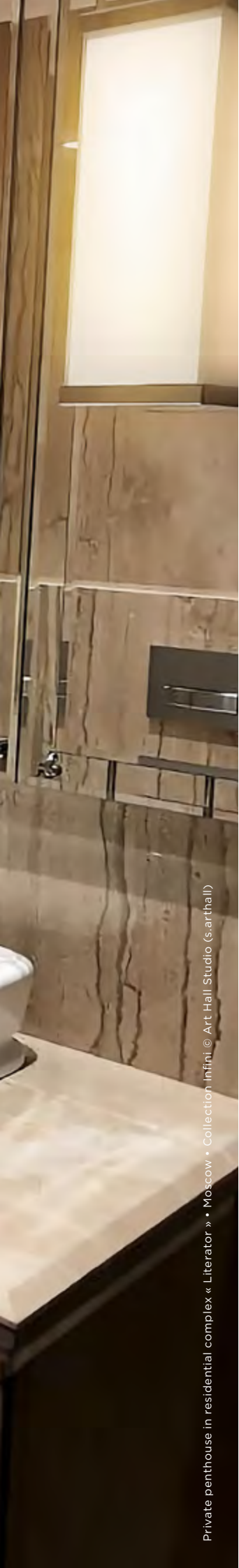

Private penthouse in residential complex « Literator » • Moscow • Collection Infini © Art Hall Studio (s.arthall)

MATIÈRE ÉLÉGANTE AU RENDU DÉLICAT,  
LA PORCELAINE SUBLIME LA SALLE  
DE BAIN. THG PARIS S'EST ENTOURÉE  
DES PLUS GRANDS PORCELAINIERS  
FRANÇAIS POUR VOUS PROPOSER  
DES COLLECTIONS UNIQUES.

AN ELEGANT MATERIAL WITH A  
DELICATE FINISH, PORCELAIN  
SUBLIMATES THE BATHROOM. THG  
PARIS HAS SURROUNDED ITSELF WITH  
THE GREATEST FRENCH PORCELAIN  
MANUFACTURERS TO OFFER YOU  
EXCEPTIONAL COLLECTIONS.

# PORCELAINE PORCELAIN



HAVILAND  
LIMOGES FRANCE 1842



# INFINI

Depuis 1842, c'est avec des gestes très précis que les artisans de la manufacture Haviland donnent sa noblesse au kaolin, l'un des principaux composants de la porcelaine. Haviland est aujourd'hui l'un des derniers porcelainiers de France à réaliser sa porcelaine dans son intégralité de la fabrication à la décoration, à Limoges ; elle fait ainsi vivre et perdurer un savoir-faire d'exception.

Since 1842, it is with very meticulous gestures that the craftsmen of the Haviland factory have given their nobility to kaolin, one of the main components of porcelain. Today, Haviland remains one of the last porcelain makers in France to produce its entire porcelain from production to decoration, in Limoges. Thus, it brings to life and perpetuates an exceptional know-how.





HAVILAND  
LIMOGES FRANCE 1842

## NIHAL



xavier cartron  
PARIS

D'un tempérament spontané et entreprenant, Xavier Cartron révèle très tôt une attirance et un enthousiasme pour l'art et l'architecture d'intérieur. Se formant auprès des Compagnons du Devoir puis d'architectes de renom, il a fait sienne des valeurs qui resteront le leitmotiv de sa vie professionnelle : la passion du travail, le respect de l'excellence et l'amour du savoir-faire.

With a spontaneous and entrepreneurial nature, Xavier Cartron reveals a particular desire and passion for art and interior architecture. He studied at "Les Compagnons du Devoir" and did his training with renowned architects. He is filled with values that will remain his daily reference of his professional life: passion for work, respect for excellence, love of know-how.





BERNARDAUD

# BERNARDAUD

PRESTIGE

## ITHAQUE

Bernardaud est le premier fabricant et exportateur de porcelaines de table français. Depuis 1863, les secrets et les techniques d'une culture deux fois millénaire s'y transmettent de père en fils. Bernardaud connaît l'alchimie et les gestes qui transforment la terre en une porcelaine d'une blancheur et d'une finesse incomparable, translucide et sonore.

Bernardaud is the leading manufacturer and exporter of French porcelain tableware. Since 1863, the secrets and techniques of a two-thousand-year-old culture have been handed down from father to son. Bernardaud is a master of the alchemy and the gestures which turn clay into an incomparably white and fine porcelain, translucent and audible.





BERNARDAUD

# MARQUISE







## MONTE CARLO



Fournisseur breveté de S.A.S. le Prince Souverain de Monaco  
By Appointment to H.S.H. the Sovereign Prince of Monaco  
**MANUFACTURE  
DE MONACO**

Depuis sa création en 1972, la Manufacture de Monaco s'emploie à fabriquer une porcelaine de première qualité. Misant sur des artisans et des créateurs hors pair, l'entreprise a su imposer un savoir-faire technique et innovant au service de la plus noble des porcelaines. Depuis 1985, le porcelainier arbore le titre officiel de Fournisseur breveté de « S.A.S. le Prince Souverain de Monaco ».

Since their establishment in in 1972, the Manufacture de Monaco has always produced luxury quality porcelain distinguished by being very white, hard and translucent. This quality is achieved by enlisting the unique skills of expert craftsmen who use technical and innovative methods to meticulously create, manufacture and carefully finish each article. Since 1985, the Manufacture de Monaco has held the official title of "His Serene Highness the Prince of Monaco".





## FROUFROU - FRIVOLE



*PYR*

PIERRE-YVES ROCHON

Esprit boudoir pour cette collection féminine ornée d'un motif classique de l'art de la porcelaine. Les fleurs des croisillons semblent prendre du relief et s'évader du blanc immaculé de la porcelaine.

A boudoir spirit for this feminine collection decorated with a typical porcelain design. The flowers on the cross handle seem to rise up and detach themselves from the pristine white porcelain.







© Argent Design • Collection Vogue améthyste

LES COLLECTIONS PRÉCIEUSES SONT  
ORNÉES DE PIERRES FINES : JASPE  
ROUGE, MALACHITE, LAPIS LAZULI,  
AMÉTHYSTE, ONYX OU ENCORE ŒIL DE  
TIGRE. CETTE PALETTE DE COULEURS  
EST SUBLIMÉE PAR UNE FINITION OR.

THE PRECIOUS COLLECTIONS ARE  
ADORNED WITH FINE STONES:  
RED JASPER, MALACHITE, LAPIS  
LAZULI, AMETHYST, ONYX OR WITH  
TIGER'S EYE. THIS COLOR PALETTE  
IS ENHANCED BY A GOLD FINISH.

# PRÉCIEUSES PRECIOUS









PRESTIGE

# AMBOISE





# SULLY - CHEVERNY





# TROCADERO





# SANITAIRE

THG Paris poursuit l'ambition de proposer des produits complémentaires à sa robinetterie. Notre offre sanitaire regroupe baignoires, vasques et receveurs de douche, fidèles à notre ADN : sublimer l'art du bain grâce à des produits d'exception.

THG Paris pursues its ambition of offering products that complement the faucet fittings, while preserving its DNA: quality and refinement. Our sanitary products include bathtubs, basins and shower trays. The very essence of THG Paris is to enhance the art of bathing, to offer a unique moment thanks to exceptional products.





# BAIGNOIRES EN ÎLOT FREESTANDING BATHTUBS





**BAIGNOIRES À ENCASTRER BUILT-IN BATHTUBS**





**VASQUES** WASH BASINS  
MINERALSTONE | CÉRAMIQUE CERAMIC





**VASQUES MÉTAL METAL WASH BASINS**





ALLURE  
HOMME  
SPORT

CHANEL  
GEL MOUSSANT POUR LE CORPS  
ET LES CHEVEUX  
HAIR AND BODY WASH



# ACCESSOIRES

Les accessoires THG Paris sont coordonnés avec chaque collection pour créer une harmonie parfaite. Disponibles dans nos finitions classiques ou PVD, ils seront la touche finale de votre salle de bain.

THG Paris accessories are coordinated with each collection to create a perfect harmony. Available in our classic finishes or PVD treatments, they will be the final touch to your bathroom.



**ACCESSOIRES COORDONNÉS** COORDINATED ACCESSORIES

Quel que soit le style de votre robinetterie, THG Paris a développé toute une gamme d'accessoires coordonnés. Laissez libre cours à vos envies et créez ainsi la salle de bain de vos rêves.

For every range of taps you chose, THG Paris has created matching accessories. Let your imagination flow and create your dream bathroom.





**GÉNÉRIQUES** GENERIC





**MIROIRS MIRRORS**











**BECS CASCADE WATERFALLS**

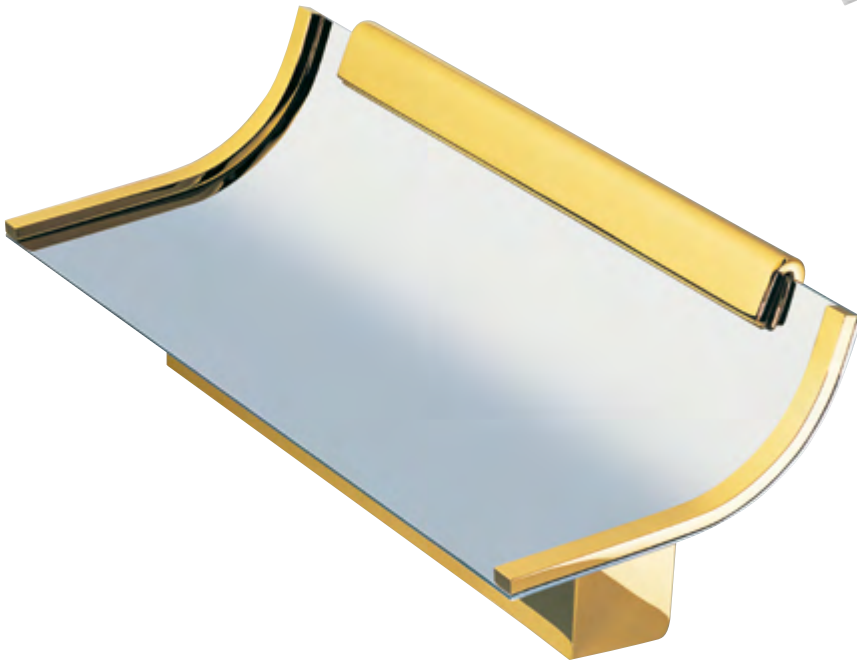



**DOUCHE SHOWER**





Lemon Dandruff  
Body Wash  
Kafun-Kafun

Fig Fiction  
Body Lotion  
Kafun-Kafun

**VIDAGES WASTES**







## SÈCHE-SERVIETTES TOWEL WARMERS

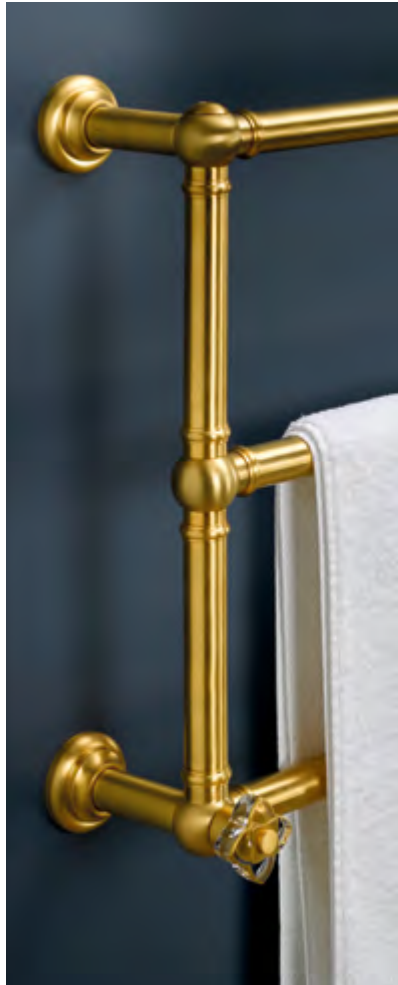

Contemporain rond ou carré, rétro lisse ou cannelé, électriques ou hydrauliques, THG Paris propose une large gamme de sèche-serviettes coordonnés à votre robinetterie.

Contemporary round or square, retro smooth or fluted, electric or hydronic, THG Paris offers a wide range of towel warmers to match your taps.



**POIGNÉES DE PORTES DOOR HANDLES**

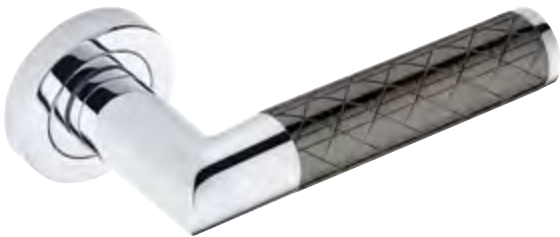



# CUISINE

THG Paris vous propose sa nouvelle gamme Cuisine. Du contemporain aux lignes épurées jusqu'au rétro chic en passant par des modèles plus traditionnels, la robinetterie THG Paris s'accorde parfaitement à l'univers de votre cuisine, qu'il soit tendance, classique ou décalé.

THG Paris is introducing its new kitchen range. Including contemporary, traditional, or retro-chic transitional ranges, our taps will dress any environment.



**MÉLANGEURS ET MITIGEURS MIXERS AND SINGLE LEVERS**



# LES FINITIONS ROBINETTERIE

## FAUCETS FINISHES

### MIX & MATCH

Grâce à l'ensemble des finitions disponibles dans la gamme THG Paris, créez la robinetterie adaptée à vos envies et sans aucune limite !

With all the finishes available in the THG PARIS range, you can create the fitting you desire.



- 1** H64 PVD couleur graphite | Graphite color PVD
- 2** F30 Or pâle | Soft gold
- >** HM2 PVD couleur graphite - Or pâle  
Graphite color PVD - Soft gold



- 1** H66 PVD couleur umber | Umber color PVD
- 2** H65 PVD couleur graphite mat | Matt graphite color PVD
- >** HK4 PVD couleur umber - PVD couleur graphite mat  
Umber color PVD - Matt graphite color PVD

Exemples d'associations de couleurs. Autres combinaisons possibles sur demande.  
Examples of colour combinations. Other combinations are available upon request.



**HH1**  
PVD nickel -  
PVD nickel mat  
Nickel PVD -  
Matt nickel PVD



**HK9**  
PVD blush -  
PVD graphite  
Blush PVD -  
Graphite PVD

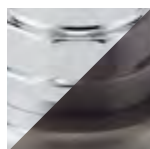

**GA9**  
Chrome - PVD  
bronze brown mat  
Polished chrome -  
Matt bronze brown  
PVD



**HF6**  
PVD nickel - PVD  
bronze brown mat  
Nickel PVD - Matt  
bronze brown PVD



**FH2**  
PVD bronze brown  
mat - PVD laiton mat  
Matt brown bronze  
PVD - Matt brass  
PVD



**HH2**  
PVD laiton mat -  
PVD laiton  
Matt brass PVD -  
Brass PVD



**GA4**  
Chrome -  
Or pâle  
Polished chrome -  
Soft gold

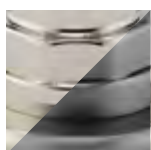

**HJ8**  
PVD nickel -  
PVD graphite mat  
Nickel PVD -  
Matt graphite PVD

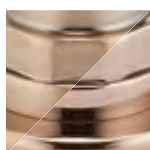

**HJ6**  
PVD umber mat -  
PVD umber  
Matt umber PVD -  
Umber PVD



**HK1**  
PVD blush mat -  
PVD graphite mat  
Matt blush PVD -  
Matt graphite PVD



**HF3**  
PVD laiton mat -  
PVD bronze brown  
Matt brass PVD -  
Bronze brown PVD



**FA1**  
Doré -  
Chrome  
Polished gold -  
Polished chrome



TRAITEMENTS CLASSIQUES | STANDARD TREATMENTS



**A02**  
Chrome  
Polished chrome



**B01**  
Nickel  
Polished nickel

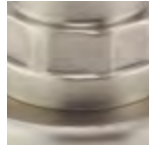

**C01**  
Nickel mat  
Matt nickel



**F30**  
Or pâle  
Soft gold



**F31**  
Or pâle mat  
Soft matt gold



**F01**  
Doré  
Polished gold



**F07**  
Doré mat  
Matt gold



**D30**  
Noir  
céramique  
Black ceram



**A13**  
Laiton fumé  
Smoked brass



**D01**  
Bronze clair  
vernis brillant  
Lacquered light  
bronze



**D05**  
Bronze clair  
vernis mat  
Lacquered  
matt bronze

TRAITEMENTS PVD | PVD TREATMENTS



**H55**  
PVD couleur  
nickel  
Nickel color  
PVD



**H56**  
PVD couleur  
nickel mat  
Matt nickel  
color PVD



**H64**  
PVD couleur  
graphite  
Graphite color  
PVD



**H65**  
PVD couleur  
graphite mat  
Matt graphite  
color PVD



**H52**  
PVD couleur  
doré  
Gold color  
PVD



**H53**  
PVD couleur  
doré mat  
Matt gold  
color PVD

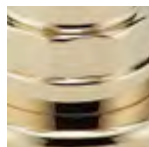

**H49**  
PVD couleur  
laiton  
Brass color  
PVD



**H50**  
PVD couleur  
laiton mat  
Matt brass  
color PVD

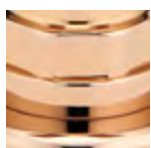

**H62**  
PVD couleur  
blush  
Blush color  
PVD

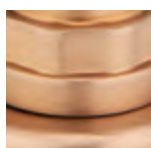

**H60**  
PVD couleur  
blush mat  
Matt blush  
color PVD

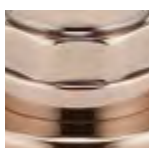

**H66**  
PVD couleur  
umber  
Umber color  
PVD

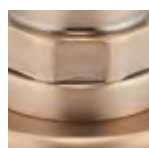

**H67**  
PVD couleur  
umber mat  
Matt umber  
color PVD



**F33**  
PVD couleur  
bronze brown  
Bronze brown  
color PVD



**F34**  
PVD couleur  
bronze brown mat  
Matt brown bronze  
color PVD

## CONTACT

### SIÈGE SOCIAL HEAD OFFICE

**THG FRANCE**  
35, rue Tournière - BP 80212  
Béthencourt-sur-Mer  
80535 Friville cedex - France  
+33 (0)3 22 60 20 80  
contact@thg.fr  
www.thg-paris.com

### FILIALES SUBSIDIARIES

**THG USA LLC**  
Head office  
441 NW - 1<sup>st</sup> avenue  
Fort Lauderdale  
FL 33301 - USA  
Tel. +1 954 425 8225  
info@thgusa.com

**THG UK**  
11 Commercial Way,  
London NW10 7XF  
United Kingdom  
Tel. +44 (0)20 8202 8288  
salesuk@thg-paris.com

**THG SINGAPORE**  
541 Orchard Road,  
#09-01 Liat Towers,  
Singapore 238881,  
Singapore  
Tel. +65 8181 5064  
rshuen@thg-paris.com

**THG ASIA**  
7/F Building 11, Phase II  
Zhong Jun Plaza,  
1688 Shenchang Road,  
Minhang District,  
Shanghai - PRC  
上海市闵行区申长路  
1688弄中骏广场二期11号楼7楼  
电话/ Tel. +86 (21) 613 527 38  
contact@thg-asia.cn

**THG RUSSIA**  
Leningradskiy avenue,  
bld. 37A, housing 14  
125167 Moscow - Russia  
Tel. +7 495 800 8225  
thg@thg-russia.ru

### SHOWROOMS THG PARIS THG PARIS SHOWROOMS

**PARIS**  
152 bd Haussmann  
75008 Paris - France  
Tel. +33 (0)1 44 20 09 20  
contact@thg-bathconcept.com  
www.thg-bathconcept.com

**LONDON**  
4 Pont Street  
London SW1X 9EL  
United Kingdom  
Tel. +44 (0)20 7838 7788  
salesuk@thg-paris.com  
london.thg-paris.com

**NEW YORK**  
D&D Building  
Showroom 1206 - 12th floor  
979 Third Avenue - New-York  
NY 10022 - USA  
Tel. +1 (917) 242 8911  
info@thgusa.com

**FRANKFURT**  
Gutleutstr. 96  
60329 Frankfurt/Main  
Deutschland  
Tel. +49 (0)69/ 25 78 14 33  
kontakt@thg-paris.com

**DUBAI**  
Dubai Design District  
Building 1A, Office 404  
Dubai - UAE  
Tel. +971 4 580 5716  
contact.me@thg-paris.com

**MILANO**  
Via Fiori Chiari 5  
20121 Milano  
Italy  
Tel. +39 02 4945 0575  
thgitaly@thg-paris.com

### CRÉDIT CREDIT

**CONCEPTION ET RÉALISATION**  
THG Paris

**PHOTOS**  
Didier Grieu  
(sauf mention spéciale)

**IMPRESSION**  
Imprimerie Jean Bernard

Textes et photos non contractuels et susceptibles d'être modifiés sans préavis  
Text and pictures are not binding and can be modified without any previous notice



Entreprise  
du Patrimoine  
Vivant  
L'excellence  
des savoir-faire  
français





THG<sup>®</sup>  
P A R I S  
[THG-PARIS.COM](http://THG-PARIS.COM)